

BRICK VENEER SUPPORT FOR EXTERIOR CHIMNEYS

by

R. Zmave
A. Goyal
M. A. Hatzinikolas

The authors are, respectively, Former Research Associate, Research Associate, and Executive Director with the Canadian Masonry Research Institute, Suite 200, 10712 - 176 St., Edmonton, AB, Canada T5S 1G7

November 1993

**CANADIAN
MASONRY
RESEARCH
INSTITUTE**



BRICK VENEER SUPPORT FOR EXTERIOR CHIMNEYS

For a number of years, many homes have been constructed using prefabricated metal chimneys to vent furnaces, wood stoves, wood and gas prefabricated fireplaces. These prefabricated metal chimneys are typically enclosed with a wood framed chase and clad in either stucco or siding. Although selected for convenience or slightly lower cost over an all masonry design, the resulting box chase often detracts from the appearance of the home.

Using the information contained in this technical note, it is possible to add brick over an existing wood frame and stucco/siding chase. This will add considerable resale value to the home due to the attractive feature chimney.

Support for Brick Veneer Around Wood Frame Chase

Usually, the wooden frame chase is supported either on a cantilevered support or on the concrete foundation, as shown in Figures 1 and 2.

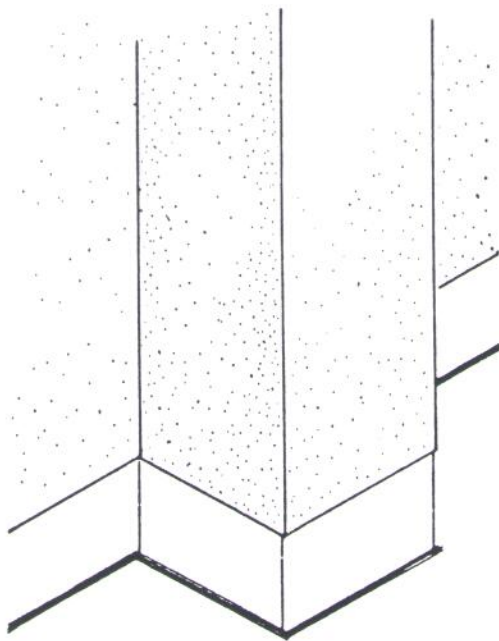

Figure 1: Wood frame chase supported on concrete foundation.

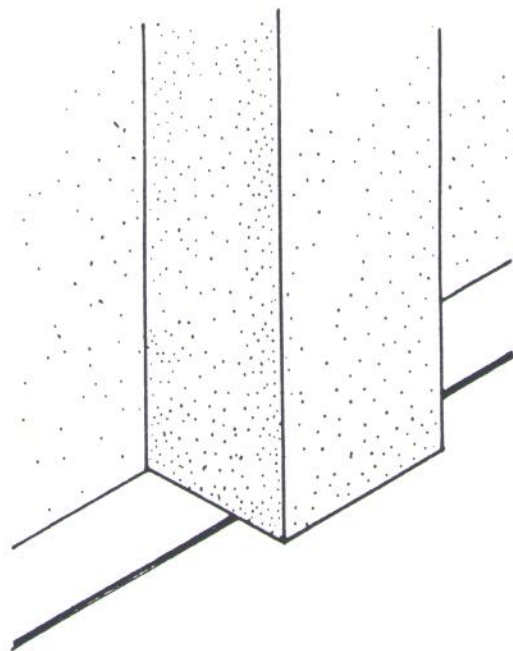
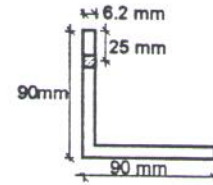

Figure 2: Wood frame chase supported by cantilevered joists.

For the type of chimney shown in Figure 1, brick veneer can be added by fastening an angle iron to the concrete foundation using the guidelines of Table 1. The guidelines provided by Table 1 can be used to support brick veneer for walls also. The minimum number of bolts per side should not be less than 2. The brick veneer should be fastened to the frame of the existing chase by means of masonry ties spaced no further apart than 400 mm (horizontal) by 600 mm (vertical). Figure 3 shows the details of this type of retrofit.

Table 1: Anchoring 90 mm x 90 mm x 6.2 mm angle iron to provide support for brick veneer

Height of Brick, m	Drop-In Anchor		Wedge Anchor	
	1/2" Dia.	5/8" Dia.	1/2" Dia.	3/8" Dia.
1.2	1.10 m	1.20 m	1.20 m	1.20 m
1.8	0.70 m	1.20 m	1.10 m	1.20 m
2.4	0.50 m	0.90 m	0.80 m	1.10 m
3.0	0.45 m	0.70 m	0.60 m	0.90 m
3.6	0.35 m	0.60 m	0.50 m	0.75 m
Min. Embedment	50 mm	60 mm	60 mm	70 mm
Min. Edge Distance	65 mm	80 mm	65 mm	80 mm



Note: Install angle iron as shown to right of Table 1, never with horizontal leg at top

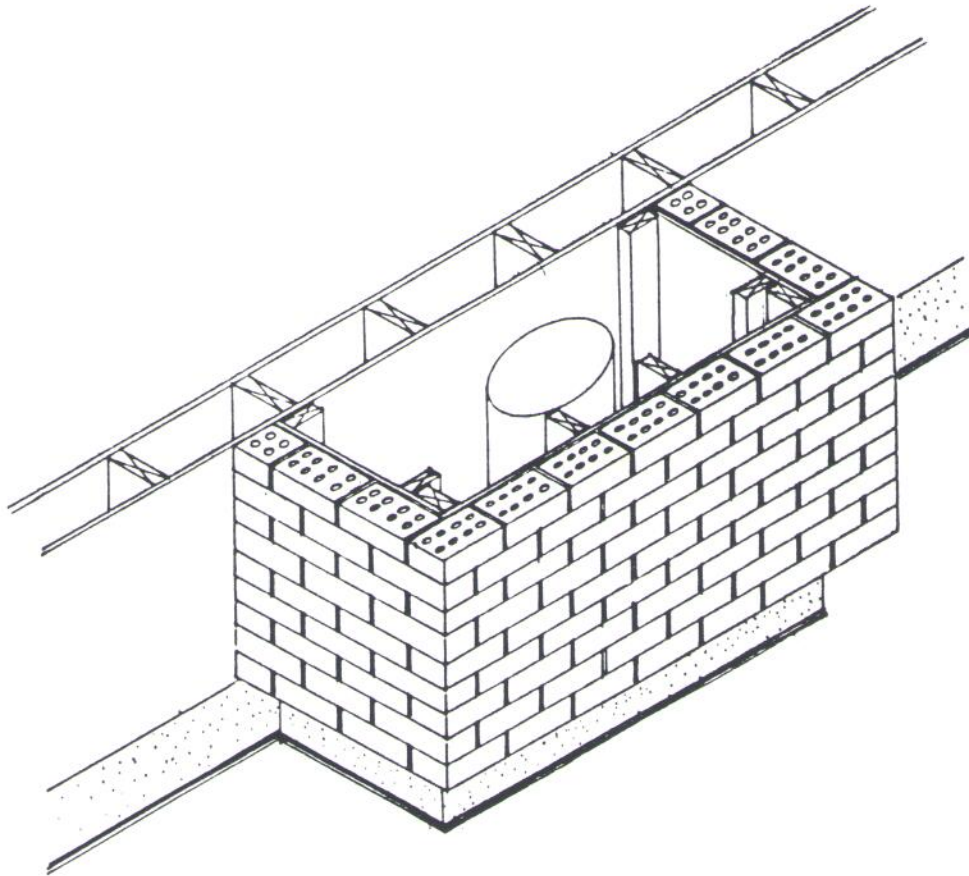

Figure 3 Details of chimney supported on concrete foundation.

For chimneys constructed as shown in Figure 2, the application of a brick veneer will require fastening of a angle iron bracket, shown in Figure 4.

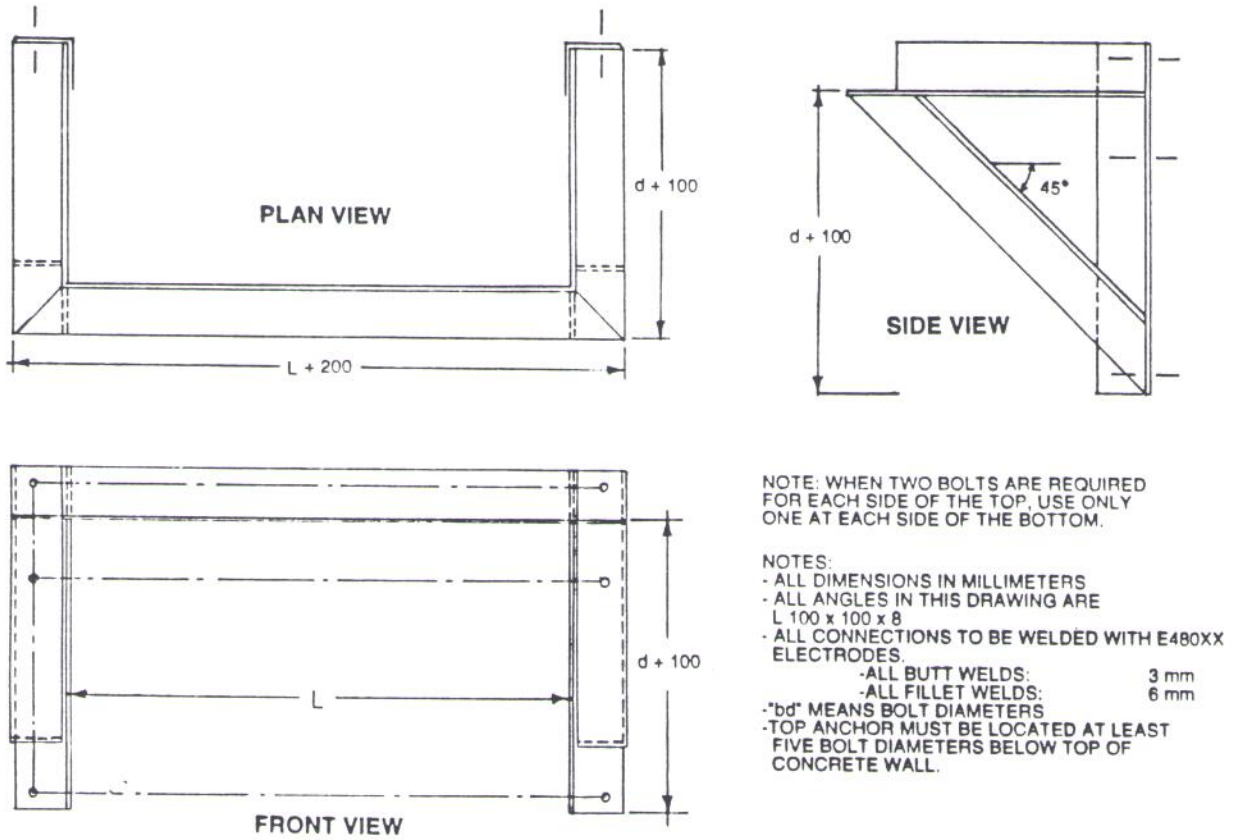

Figure 4: Metal bracket for retrofitting wood frame chase

Table 2 contains design guidelines of the bracket from where the number of anchor bolts and their location can be obtained as a function of the length L, the height of the chase and the size of the anchor.

Table 2: Design guidelines of support bracket

L (mm)	d (mm)	1/2" Diameter										3/8" Diameter										3/4" Diameter									
		7.0 kN/Anchor										9.3 kN/Anchor										13.8 kN/Anchor									
		10.1 kN/Anchor										13.6 kN/Anchor										21.4 kN/Anchor									
		Height (m)										Height (m)										Height (m)									
		3	4	5	6	7	8	9	10	11	3	4	5	6	7	8	9	10	11	1	4	5	6	7	8	9	10	11			
400	300	1	1	1	1	1	1	1	1	1	1	1	1	1	1	1	1	1	1	1	1	1	1	1	1	1	1	1			
	400	1	1	1	1	1	1	1	2	2	1	1	1	1	1	1	1	1	1	1	1	1	1	1	1	1	1	1			
	500	1	1	1	1	1	1	2	2	2	1	1	1	1	1	1	1	1	1	1	1	1	1	1	1	1	1	1			
	600	1	1	1	1	1	2	2	2	2	1	1	1	1	1	1	1	1	2	1	1	1	1	1	1	1	1	1			
	700	1	1	1	1	2	2	2	2	2	1	1	1	1	1	1	1	2	2	1	1	1	1	1	1	1	1	1			
600	300	1	1	1	1	1	1	1	2	2	1	1	1	1	1	1	1	1	1	1	1	1	1	1	1	1	1	1			
	400	1	1	1	1	1	1	2	2	2	1	1	1	1	1	1	1	1	1	1	1	1	1	1	1	1	1	1			
	500	1	1	1	1	1	2	2	2	2	1	1	1	1	1	1	1	1	2	1	1	1	1	1	1	1	1	1			
	600	1	1	1	1	2	2	2	2	2	1	1	1	1	1	1	1	2	2	1	1	1	1	1	1	1	1	1			
	700	1	1	1	1	2	2	2	2	2	1	1	1	1	1	1	2	2	2	1	1	1	1	1	1	1	1	1			
800	300	1	1	1	1	1	1	2	2	2	1	1	1	1	1	1	1	1	1	1	1	1	1	1	1	1	1	1			
	400	1	1	1	1	1	2	2	2	2	1	1	1	1	1	1	1	1	2	1	1	1	1	1	1	1	1	1			
	500	1	1	1	1	2	2	2	2	2	1	1	1	1	1	1	1	2	2	1	1	1	1	1	1	1	1	1			
	600	1	1	1	1	2	2	2	2	2	1	1	1	1	1	1	2	2	2	1	1	1	1	1	1	1	1	1			
	700	1	1	1	2	2	2	2	2	2	1	1	1	1	2	2	2	2	2	1	1	1	1	1	1	1	1	2			
1000	300	1	1	1	1	1	2	2	2	2	1	1	1	1	1	1	1	1	2	1	1	1	1	1	1	1	1	1			
	400	1	1	1	1	2	2	2	2	2	1	1	1	1	1	1	1	2	2	1	1	1	1	1	1	1	1	1			
	500	1	1	1	1	2	2	2	2	2	1	1	1	1	1	1	2	2	2	1	1	1	1	1	1	1	1	1			
	600	1	1	1	2	2	2	2	2	2	1	1	1	1	1	2	2	2	2	1	1	1	1	1	1	1	1	1			
	700	1	1	1	2	2	2	2	2	2	1	1	1	1	2	2	2	2	2	1	1	1	1	1	1	1	1	2			
1200	300	1	1	1	1	2	2	2	2	2	1	1	1	1	1	1	1	2	2	1	1	1	1	1	1	1	1	1			
	400	1	1	1	1	2	2	2	2	2	1	1	1	1	1	1	2	2	2	1	1	1	1	1	1	1	1	1			
	500	1	1	1	2	2	2	2	2	2	1	1	1	1	1	2	2	2	2	1	1	1	1	1	1	1	1	1			
	600	1	1	1	2	2	2	2	2	2	1	1	1	1	1	2	2	2	2	1	1	1	1	1	1	1	1	1			
	700	1	1	2	2	2	2	2	2	2	1	1	1	1	2	2	2	2	2	1	1	1	1	1	1	1	1	2			

Figure 5 and 6 show the details of the retrofit.

EXAMPLE:

FOR AN EXISTING CHIMNEY 6000 mm HIGH, 600 mm WIDE (L) AND 500 mm IN DEPTH (d). USE FRAME FOR SUPPORTING THE BRICK VENEER AT THE FOUNDATION CONSTRUCTED AS SHOWN, AND USE ONE 12 mm DIAMETER REDHEAD 'WEDGE' ANCHOR BOLT AT EACH TOP SIDE OF THE FRAME. USE THE SAME ANCHORS FOR BOTTOM.

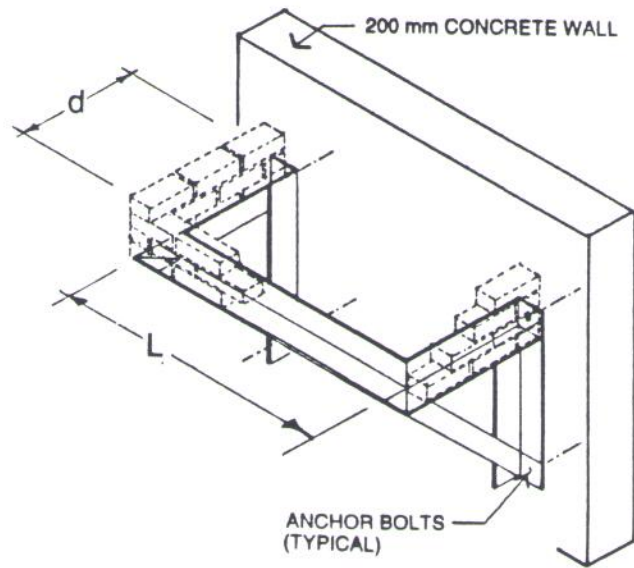

Figure 5: Isometric view of the cantilever support

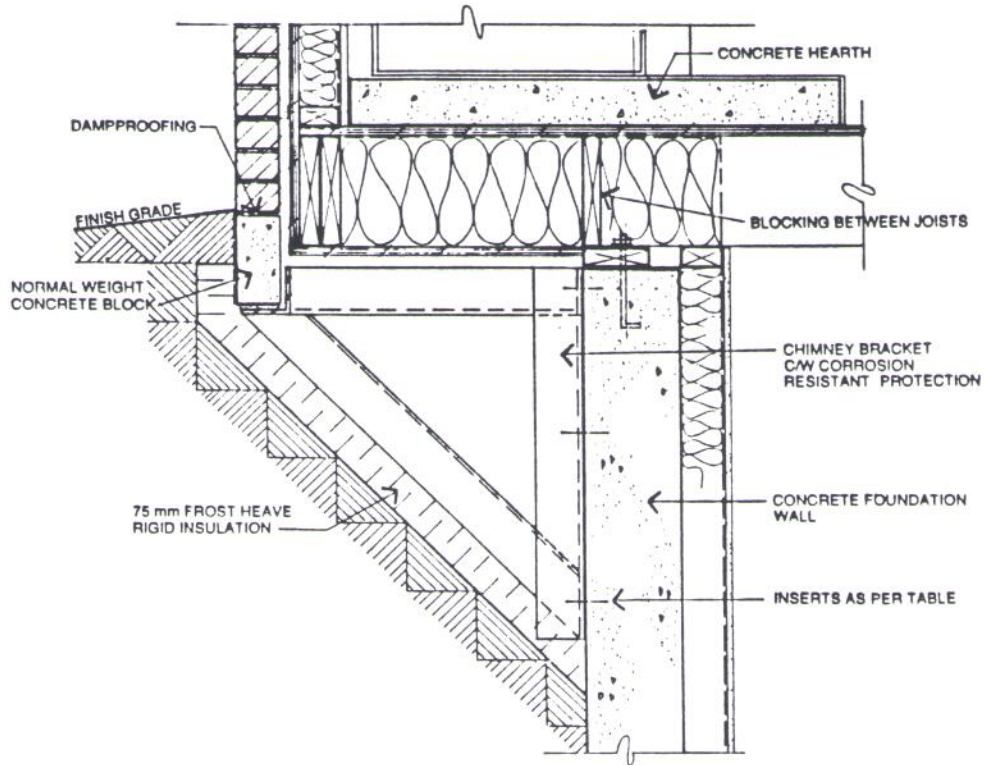

Figure 6: Connection details of the cantilever support

The veneer is tied to the frame of the wood chase by using 0.76 mm (22 ga.) standard corrugated strip ties and 3.18 mm diameter spiral nails (having a minimum wood penetration of 63 mm), spaced at 600 mm vertically and 400 mm horizontally. The incorporation of 25 mm airspace between the brick and the existing chase is recommended. Figure 7 shows these details.

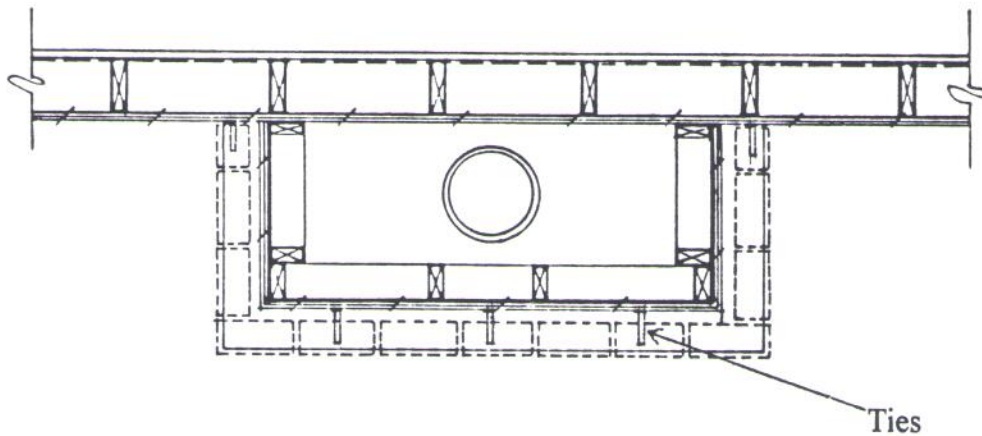

Figure 7: Section through retrofitted chimney

Support Chimney on Top of Roof

Use 100 mm x 100 mm x 8 mm (or 6 mm) angle iron supported by the brick veneer on both ends and anchored to wood studs by 5/8" bolts @ 400 mm spacing. Cut through roof and add flashing if required. Figure 7 shows these details.

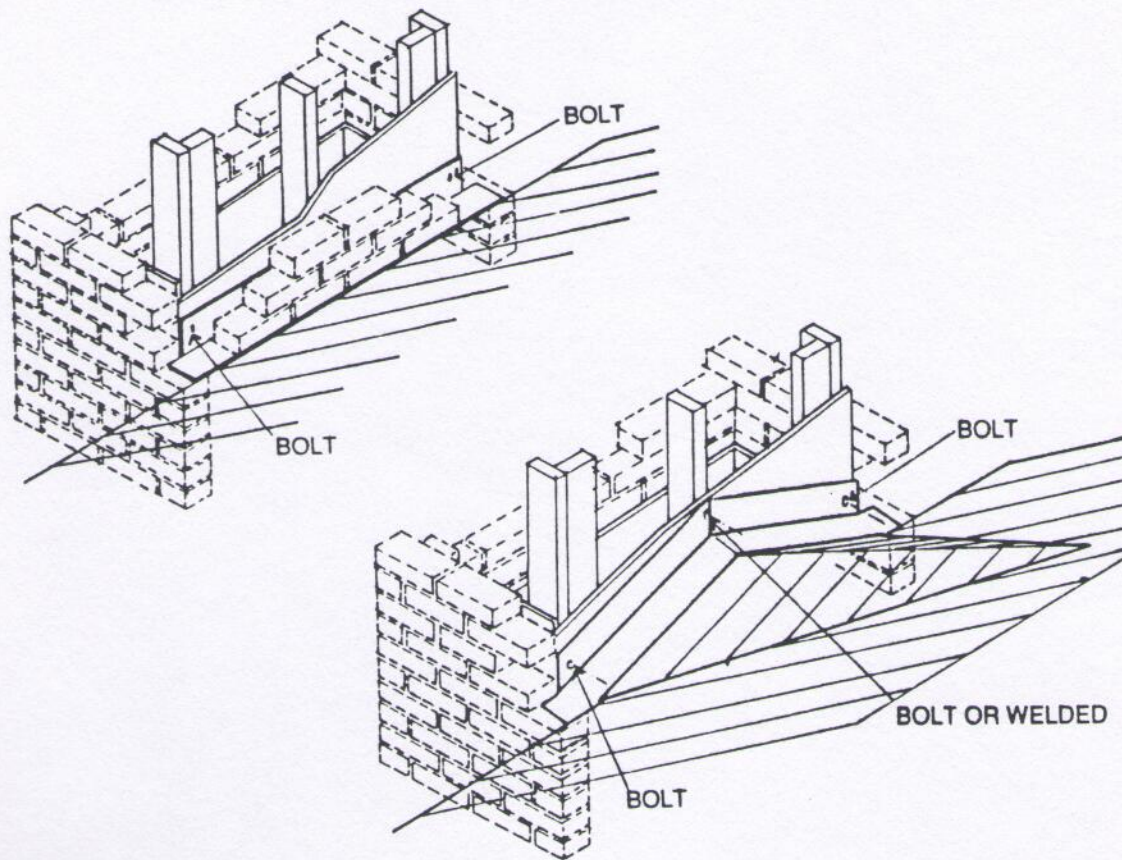

Figure 7: Brick veneer around the chimney at the top

Capping of Chimney

The chimney may be capped with a metal coping or a poured-in-place concrete cap with a flashing beneath it. Silicone caulking should be used at the chimney-cap junction. Figure 8 shows the capping details.

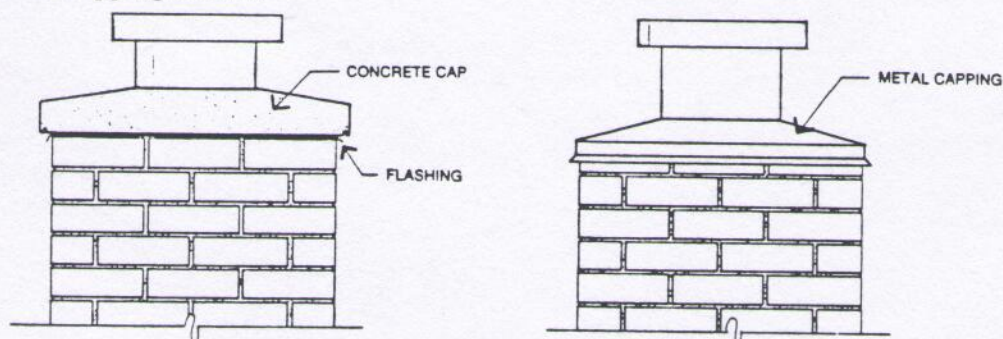

Figure 8: Typical capping details