

*FRESH AIR INTAKE  
FOR  
FIREPLACES*

by

M.A. Hatzinikolas, Ph.D., P.Eng.\*

\* Executive Director  
Canadian Masonry Research Institute, Edmonton, Alberta

**CANADIAN  
MASONRY  
RESEARCH  
INSTITUTE**



FRESH AIR INTAKE FOR FIREPLACES

August 1983

Prepared By:

DR. M.A. HATZINIKOLAS, P. ENG.

## TABLE OF CONTENTS

	Page no.
Acknowledgements	
Introduction	1
Design Considerations	2
Energy Considerations	2
Development of the Fresh Air Intake	4
Installation	5
Evaluation of the Device	6
Conclusions	9
Future Plans	10
Appendix 'A'	11
Design Details	12
Photographs	19
Test Results	23
Appendix B	24
Top Mounted Fireplace Damper	25

## ACKNOWLEDGEMENTS

The interest in the project by the Alberta Department of Housing and the financial support provided is gratefully acknowledged. In particular, I would like to thank Mr. Linden Holmen, Mr. Robert Sloat, and Mr. Bryan Poulin, all of the Alberta Department of Housing, Policy and Research Division for their encouragement and support.

Also the contribution and discussions with Mr. Frank Cass, Mechanical Supervisor, Building Standards Branch, General Safety Service Division of Alberta Labour, provided valuable assistance in selecting materials and establishing guidelines with regards to dimensions of the various parts of the device.

## INTRODUCTION

Fuel burning devices such as furnaces, wood stoves, fireplaces use air for combustion. Furnaces normally have a separate air duct to the outside for the supply of make-up and combustion air, while fireplaces and wood stoves rely on drawing air from the surrounding areas for combustion and make up air.

Combustion air is air that is required to keep the fire burning and make-up air is the air required to replace warm air that disappears through the exhaust pipe or chimney.

Because of the increased awareness between air tightness and energy conservation, homes and other buildings are designed or retrofitted to increase the air tightness.

The reduction of the air infiltration in homes may result in insufficient supply of combustion and make-up air to adequately operate a fireplace. Lack of adequate air supply to fireplaces may cause hazardous conditions due to lowering of the air pressure within the house. This can result in improper combustion, smoking of the fireplace and reversal of flow in exhaust systems of other appliances such as furnaces and dryer vents.

In homes where air can infiltrate around doors, windows and other discontinuities in the vapour barrier and air seal, the fireplace can be operated properly. The uncontrolled supply of combustion and make-up air can cause drafts and cooling of other areas of the house. Drafts are the result of cold air infiltrating into the building to replenish the air used for combustion or the warm inside air that 'goes up the chimney'.

This report contains the Author's design considerations for a fresh air supply system for fireplaces as well as the test results of some prototypes.

### DESIGN CONSIDERATIONS

When combustion air is supplied to a fireplace a number of requirements must be satisfied. The most important ones are as follows:

1. The amount of air must be controlled.
2. The fresh air supply must be opened and closed as required.

By controlling the amount of air, the oxygen supply to the fire is regulated and the rate of combustion is controlled.

By closing off the fresh air supply system in the fire box and at the point where the outside fresh air enters the duct, the fireplace will cool down at a slower rate as the locked-in air in the duct has some insulating value. If the fresh air supply system is closed off only in the firebox, condensation can occur which may cause deterioration of the masonry and it can also lead to energy loss due to cold convection drafts.

The fresh air supply system that is developed, allows the fresh air supply in the fire box and the outside air intake, to be closed off in one operation from the inside. This is very practical in the winter season when fireplaces are used more often.

### ENERGY CONSIDERATIONS

The velocity of air entering the opening of a fireplace during operation is reported to be in the order of 0.244 to 0.305 m/s (0.8 to 1.0 ft/sec.). For a common fireplace with an opening measuring 0.610 x 0.89 m (24 x 35 inches), the volume of air passing through the

opening assuming an air velocity of 0.224 m/s (0.9 ft/sec.) will be:

$$0.610 \times 0.889 \times 0.274 = 0.1486 \text{ m}^3/\text{s} \text{ (5.25 cu. ft./sec.)}$$

If the fireplace is in operation for two hours the volume of air which will enter the fire box for combustion and make-up air requirements will be in the order of:

$$0.1486 \times 60 \times 60 \times 2 = 1,069 \text{ m}^3 \text{ (37784 cu. ft.)}$$

In a conventional fireplace installation all of this air has to enter the house from the outside through windows, doors, etc. Assuming an outside temperature of  $-26^\circ\text{C}$  ( $-15^\circ\text{F}$ ), the energy required to increase the temperature of this air to  $21^\circ\text{C}$  ( $70^\circ\text{F}$ ) is approximately  $1069.9 (21 + 26) \times 1207 = 60,943.6 \text{ KJ}$  (57,530 Btu)

This energy is approximately equivalent of  $1.64 \text{ m}^3$  (57.8 cu. ft) of natural gas, assuming that  $1 \text{ m}^3$  of natural gas provide  $37.257 \text{ mJ}$  and that  $1207 \text{ J}$  are required to increase the temperature of  $1 \text{ m}^3$  of air by one degree Celsius.

One of the reasons a fireplace is not an efficient heating device is that it gives mainly directional radiant heat. Radiant heat warms up objects, not air. If you stand in front of a fireplace in an ice-cold room, you can roast your front and freeze your back. Most heat produced in a conventional fireplace is lost up the chimney, and the little heat that enters the room is not very effective.

A better method to extract heat from a fireplace is convection. Convective heat will warm up air and not objects. Base board heating and air from the forced air furnace use convective heat.

The closest a fire in the fireplace comes to producing convective heat is the heat given off by the fire brick walls of the fire box. Users of fireplaces learned early that this kind of heat was desirable and the fire brick was developed to produce more convective heat.

With a properly fitted glass door and a supply of combustion air a fireplace can become an energy efficient device as will be demonstrated

in the following example.

Assume that an average fireplace consumes one cord of air dried wood over a period of two months (this has approximately the same heating capacity as 680 l (150 imperial gallons) of number 2 oil or 680 m<sup>3</sup> (24,000 cu. ft.) of natural gas).

Assuming further that this fireplace is equipped with glass doors, a fresh air supply system and that 50% of the heat produced will be transferred into the surrounding space in the form of radiant and convective heat, the energy saving will amount to 340 m<sup>3</sup> (12,000 cu. ft.) of natural gas. By providing the required outside air, the loss of energy is eliminated. If the fireplace is equipped with a fresh air supply system, glass doors and a top mounted chimney damper\* it becomes an energy efficient appliance. The efficiency of fireplaces can also be improved by many design features, such as an electric fan, which circulates air through ducts and can easily be incorporated in new fireplaces.

#### DEVELOPMENT OF THE FRESH AIR INTAKE

The materials used in fabricating the device are non-combustible and meet all existing code and performance requirements. The device is shown schematically in figures 1 through 6 on pages 14 through 19.

\* When the fireplace is not in operation, some air can escape up the chimney, which combined with convection drafts will increase energy consumption. To eliminate this movement of air, a top mounted chimney damper can be installed. Presently such a top mounted chimney damper is manufactured and is now available in a number of Canadian cities. The Alberta distributors of these devices and information on this chimney damper are shown in Appendix B of this report.



The operation of the device is easy and all parts are accessible for easy maintenance or replacement should the need arise after installation. The two main parts are identical both in design and dimension, which facilitates fabrication and keeps down the cost.

The diameter of the pipe connecting the 2 main elements is 127 mm (5 inches). When required a larger diameter can be used. The minimum thickness of the sheet metal to fabricate the device is 32 gauge, but for practical reasons 26 gauge is more suitable. The shutters are fabricated from 22 gauge sheet metal in order to prevent warping when hot. A screen cover at the exterior intake will ensure that no insect or birds enter the duct.

The device is operated by lifting the interior shutter which is connected to the exterior one. A screen at the interior shutter prevents ashes from falling in the connecting duct and box.

#### INSTALLATION

The device can be installed during the construction of new fireplaces or retrofitted in existing masonry fireplaces, fireplaces with metal inserts or zero clearance metal fireplaces. When the device is installed in masonry fireplace, it must be placed inside the fire box in such a way that it does not interfere with the installation and operation of glass doors. In this case the device must be inside the hearth when the doors are closed. In zero clearance fireplaces the device must be installed in such a way that it does not interfere with the main body of the fireplace.

The device can also be installed in basement fireplaces and other interior locations. This can be done by installing a connecting duct with suitable elbow connections (refer to Figure 7 for typical installation).

When the connecting duct work is not enclosed in solid masonry, suitable insulation must be provided to prevent condensation.

For installation in new fireplaces the device is pre-assembled to the length and orientation required and then placed in position. The mason then lays the bricks around the device. It is expected that this does not increase the labour required for the construction of new fireplaces.

For retrofitting, the process involves removal of the fire bricks from the floor of the fire box and removal of some exterior bricks and the creation of an opening for the connecting pipe. A total of 5 or 6 bricks will be affected on the exterior face of the fireplace.

The intake is designed in such a way that it does not require any cutting of bricks during the installation. The device is then connected and the control push and pull cable is adjusted after proper alignment. The fire bricks and exterior bricks are then rebuilt around the intakes. It will take an experienced mason approximately 4 hours to complete this kind of retrofit.

It will take a trained mason 2 to 3 installations before he can retrofit the device in approximately 4 hours.

Photographs 1 to 6 on page 21 to 23 show the various stages of a retrofit installation.

#### EVALUATION OF THE DEVICE

One of the fresh air supply systems was installed in a house in St. Albert, Alberta. The owner, a medical doctor evaluated the performance of the system. The most noticeable improvements were stable temperatures in all rooms of the house when the fireplace was burning and the elimination of smoking, which used to happen before the installation of the device. It was also reported that the hallway and bedrooms no longer dropped in temperature. During cold weather, the lighting of the fireplaces no longer caused the furnace to smoke.

This confirms earlier arguments presented in this report.

The temperature drop in the vicinity of the entrance hall was approximately 1.4°C (2.5°F) measured at a distance of 3.0 m (10.0 feet) from the door and 2.8°C (5.0°F) at 1.2 m (4 ft.) from the door.

Different results can be expected for other situations such as in houses where weather stripping is provided around doors and other openings. It is beyond doubt that the provision of fresh air to the fireplace will improve the operation of the fireplace and reduce the energy consumption of the house.

For situations where the air leaks are distributed over the total wall area of the house it may be more difficult to evaluate the beneficial effect of the supply of air with the limited testing equipment. (A common thermometer was used).

However, the need for combustion and make-up air for all fuel consuming appliances is well documented. The Building Standards Branch of Alberta Labour has been attempting for the past 5 years to make people aware of the advantages of combustion and make-up air supplies.

The National Building Code of Canada requires similar provisions. All these requirements are based on well established principles and it is for this reason that we do not want to spend too much effort in the documenting temperature gradients in houses. The temperature caused by gradients are the air infiltration to replenish combustion and make up air provided to fireplaces.

The second fresh air supply system was installed in the residence of Mr. John O'Conner, P. Eng., located in Edmonton at 1904 - 89 Street. Photographs 1 to 6 on page 21 to 23 show the various aspects of the installation of the fresh air intake.

The opening of the fireplace is 0.584 x 0.812 m (23 x 32 inches) with an area of 0.474 m<sup>2</sup> (736 square inches).

A limited experimental evaluation of the performance of the device was carried out. First the device was closed with the fire box open (ie. condition of no fire box doors or doors open). The average velocity of air entering the fire box is 0.253 m/s (0.83 ft./sec.).

The air was supplied from a 0.055 m<sup>2</sup> (85 square inch) opening in the window which was intentionally left open. The velocity of the air, entering at the window opening was 1.905 m/s (6.25 ft./sec.).

The total amount of air entering the fire box is:

$$0.253 \times 0.474 = 0.112 \text{ m}^3/\text{s} \text{ (3.96 cu. ft. per sec.)}$$

The total amount of air entering the house from the open window is:

$$0.055 \times 1.905 = 0.105 \text{ m}^3/\text{s} \text{ (3.71 cu. ft. per sec.)}$$

The difference of 0.007 m<sup>3</sup>/s (0.25 cubic feet per second) was most likely supplied by other sources such as openings around door and window frames. When the fresh air intake was fully opened and the fire box open (ie. condition of glass doors open) the air velocity measured at the intake of the fresh air supply device was approximately 0.635 m/s (2.08 ft. per sec.).

When the fire box was closed as shown in Photo 6, on page 23, the fresh air supply device provided all the combustion air. The air velocity measured at the exterior intake was 2.16 m/s (7.08 ft. per sec.). The total air flow through a 100 mm diameter duct is:

$$2.16 \times 3.14 \times (0.1:2)^2 = 0.017 \text{ m}^3/\text{s} \text{ (0.6 cu. ft. per sec.)}$$

(It was observed that some air was leaking into the fire box from openings between the brick, mortar joints and enclosure). The locations of measurements and test results are presented in Appendix A (Figure 8 and Table 1). These preliminary findings suggest that a

127 mm (5 inches) diameter connecting pipe would provide 0.027 m<sup>3</sup>/s (0.97 cu. ft. per sec.) of combustion air which is considered sufficient to sustain the fire. Because of the small temperature difference between the outside and inside of the house at the time of testing and the relatively small height of the chimney, the air flows obtained from these tests are conservative. The installation of properly fitted glass doors, simulated in this test by placing a metal closure over the fireplace opening (see Photo 7 on page 23), will make the fresh air intake effective by increasing the air flow through the device and also by reducing the need for make up air. It should be stated here that although the device can provide all of the combustion air and eliminate the requirement for make-up air from the house, it cannot be expected to eliminate the movement of air through the fireplace opening when no glass doors are provided. It is for this reason that the American Society of Heating, Refrigeration and Air Conditioning Engineers (ASHRAE) requires a 229 mm (9 inches) diameter air supply or equivalent to the flue area unless glass doors are provided.

Because of space limitations it is only practical to install a supply pipe of up to 127 mm (5 inches) in diameter for retrofit applications. In this case the presence of glass doors is recommended in order to ensure that the combustion air is supplied by the fresh air supply device. Even if a larger diameter air supply ducts were installed in a new fireplace, glass doors are highly recommended.

### CONCLUSIONS

The installation of a fresh air supply system, to supply air for combustion in fireplaces, will improve their energy efficiency. The device developed performs satisfactorily. The ability to control the air supply and the ability to provide double closure of the device are two very important features. The ability to close off the fresh air supply system at the outside and in the fire box are two important features.

APPENDIX A

DESIGN DETAILS PHOTOGRAPHS

AND

TEST RESULTS

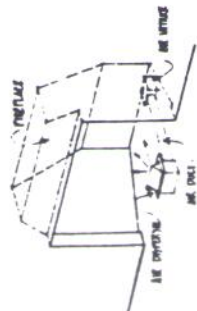
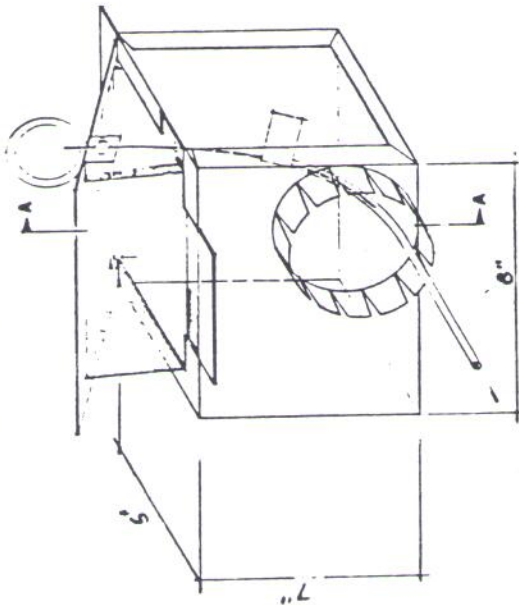
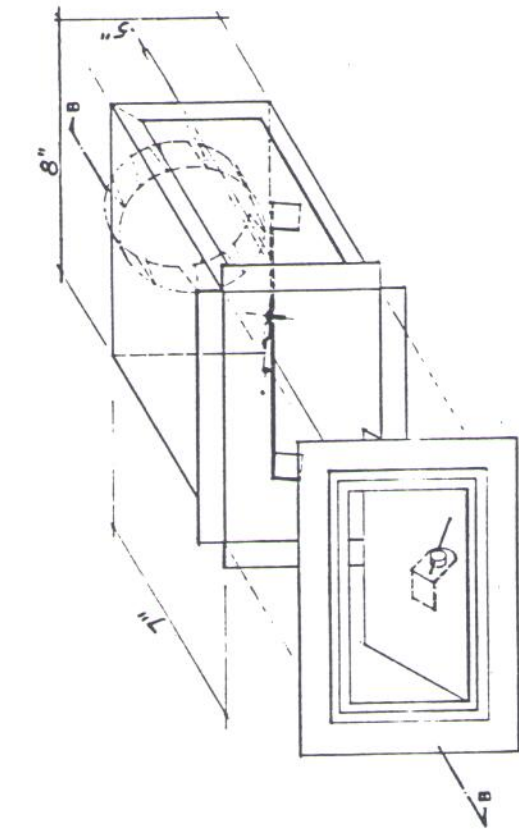

INSTALLATION  
TABLE 017

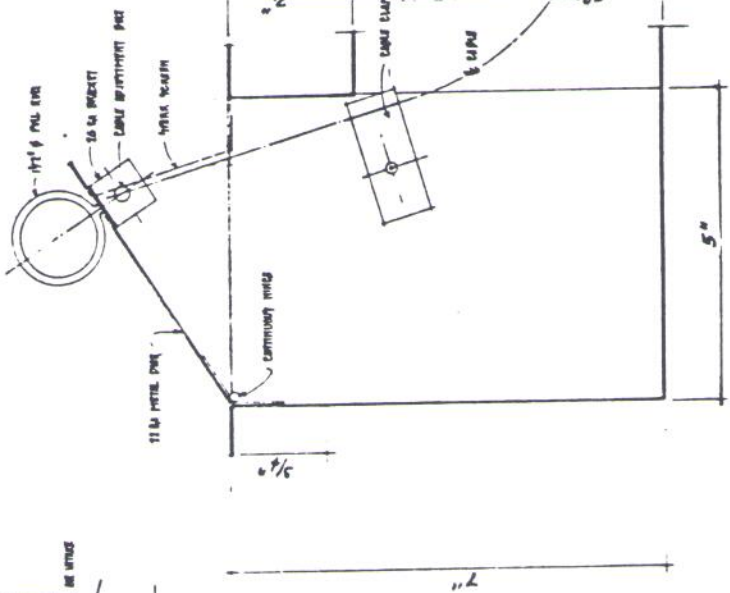

section A  
TABLE - PHL 1117

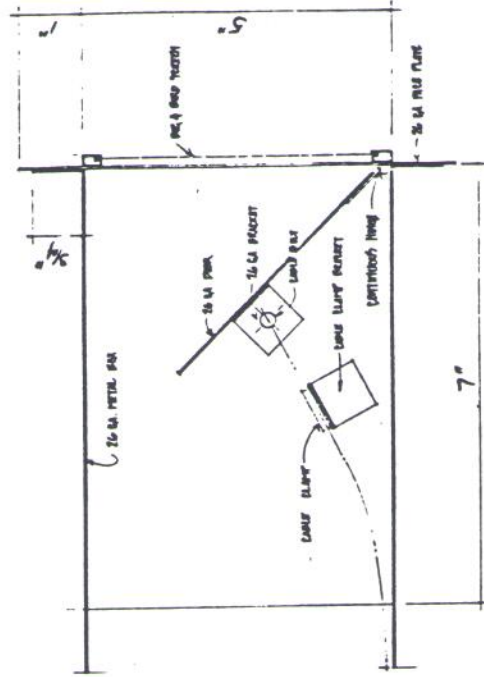

section B  
TABLE - PHL 1117

Fig. 1 - Main Elements of Fresh Air Intake

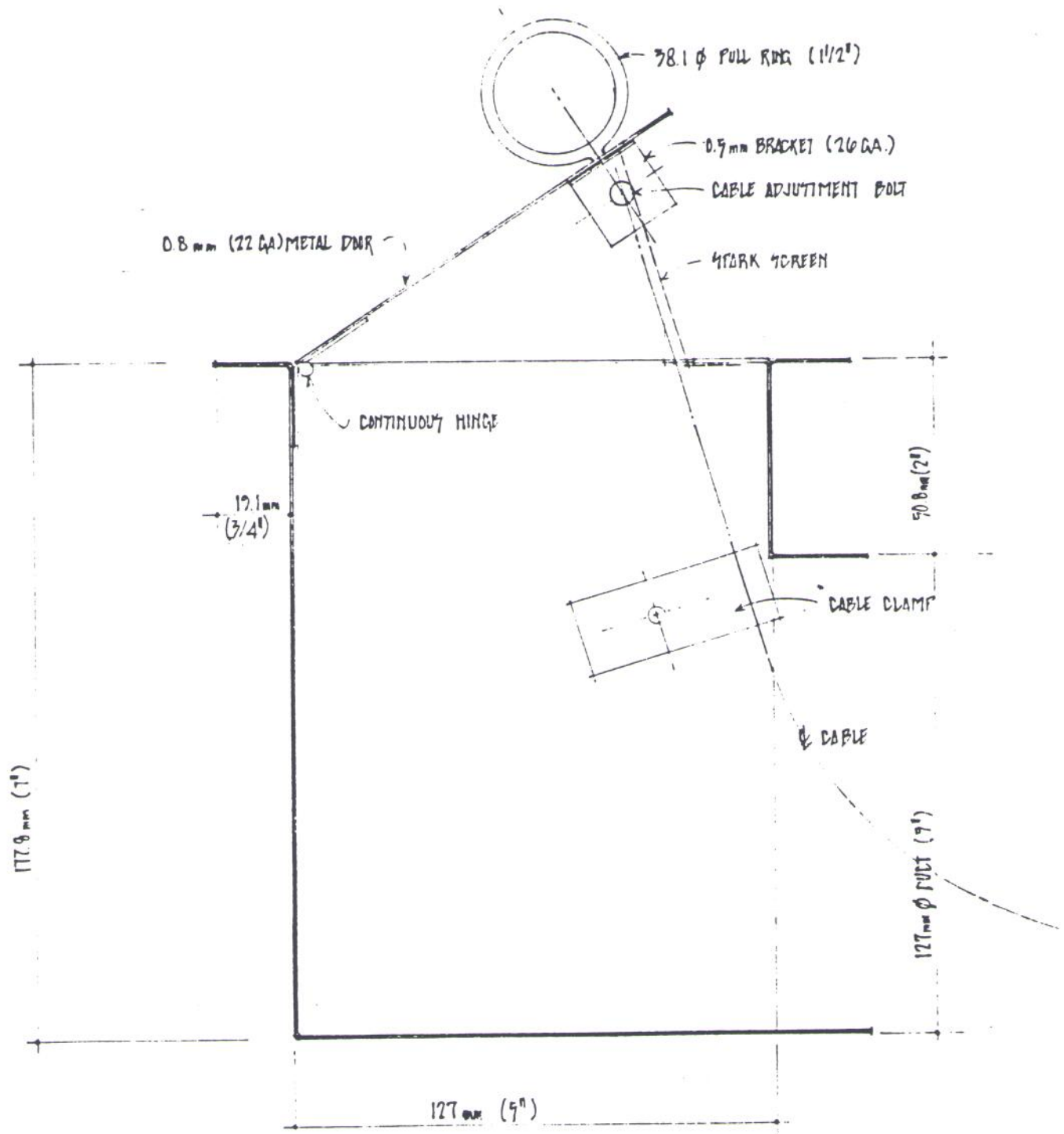

# section A

SCALE: FULL SIZE

Fig. 2 - View of Interior Box with Spark Screen.



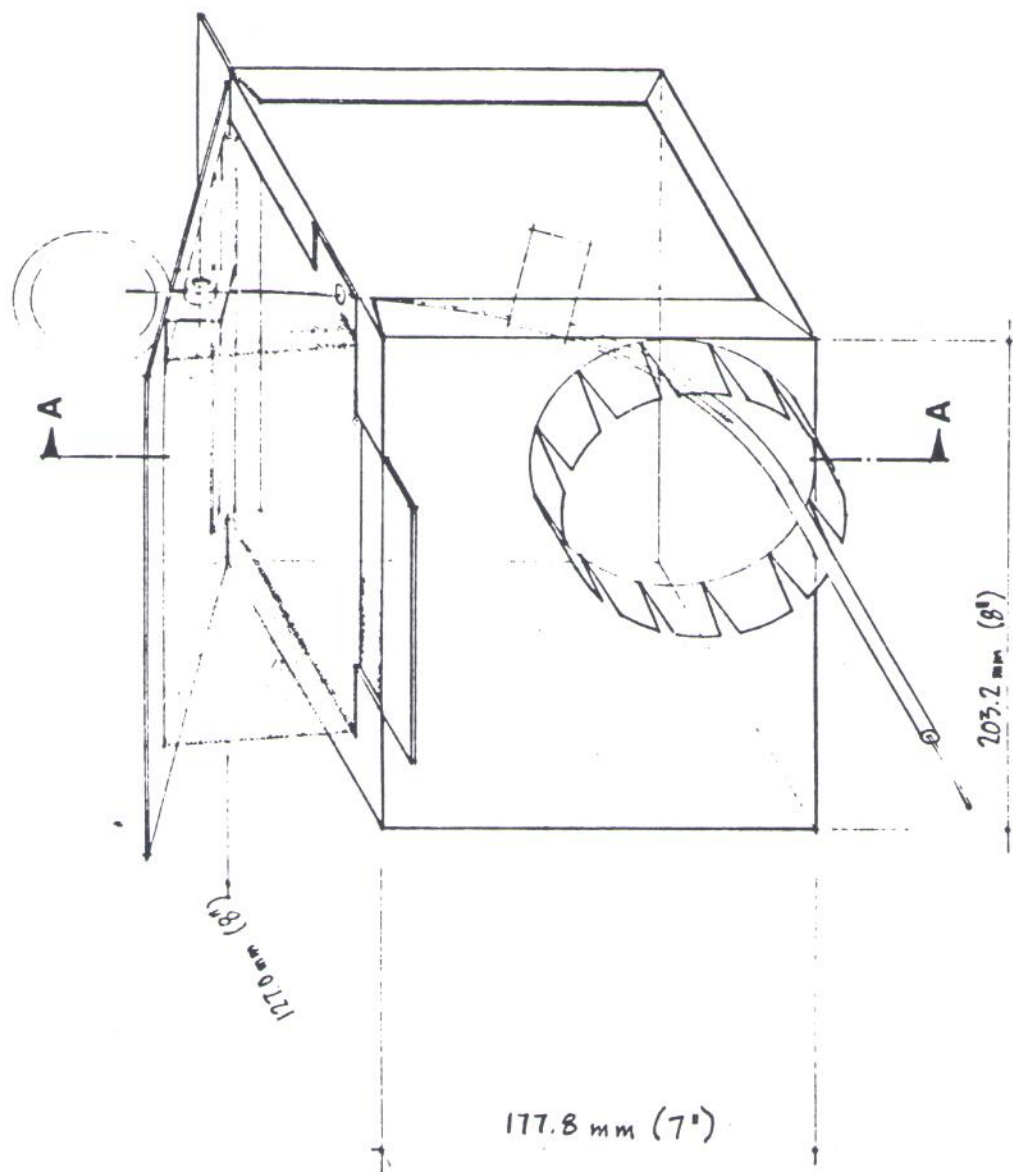
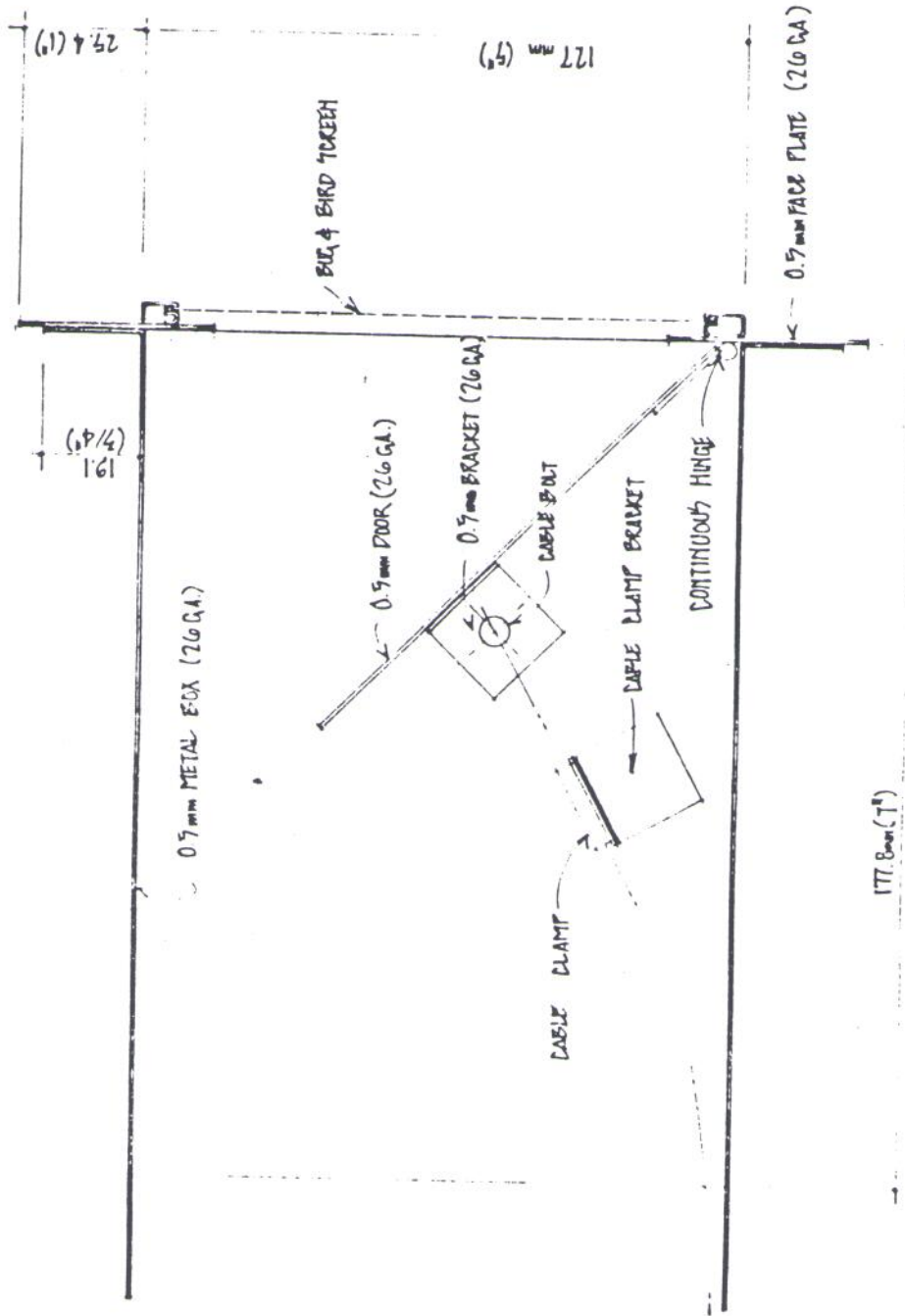

Fig. 3 - Isometric of Interior Box.



177.8mm (7")

# section B

SCALE - FULL SIZE

chkd MR dnm WJS date 10/07/87 dwg 1r

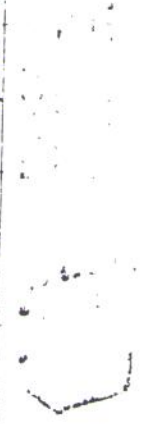

Fig. 4 - View of Exterior Box Showing Door and Accessories.

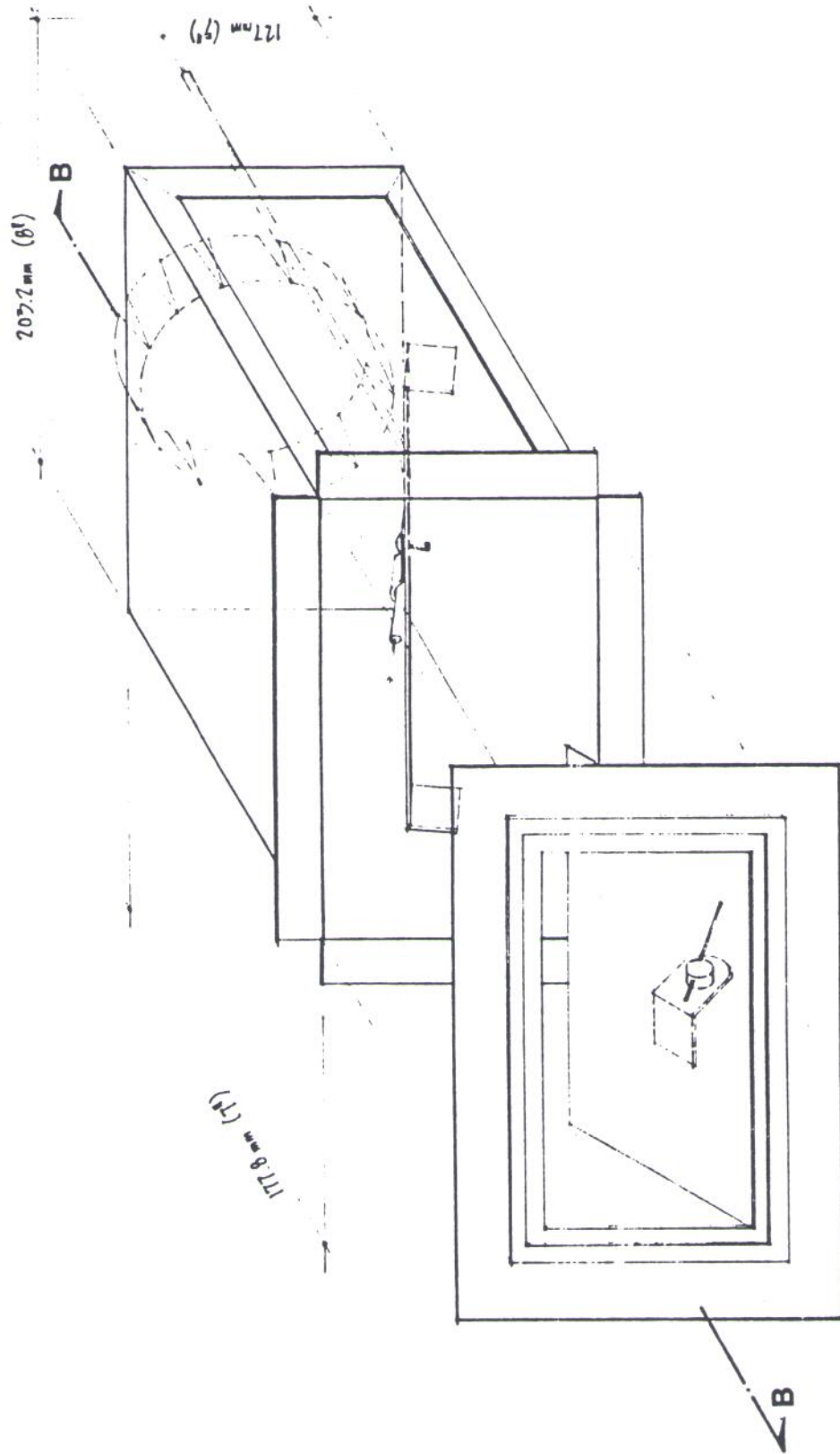
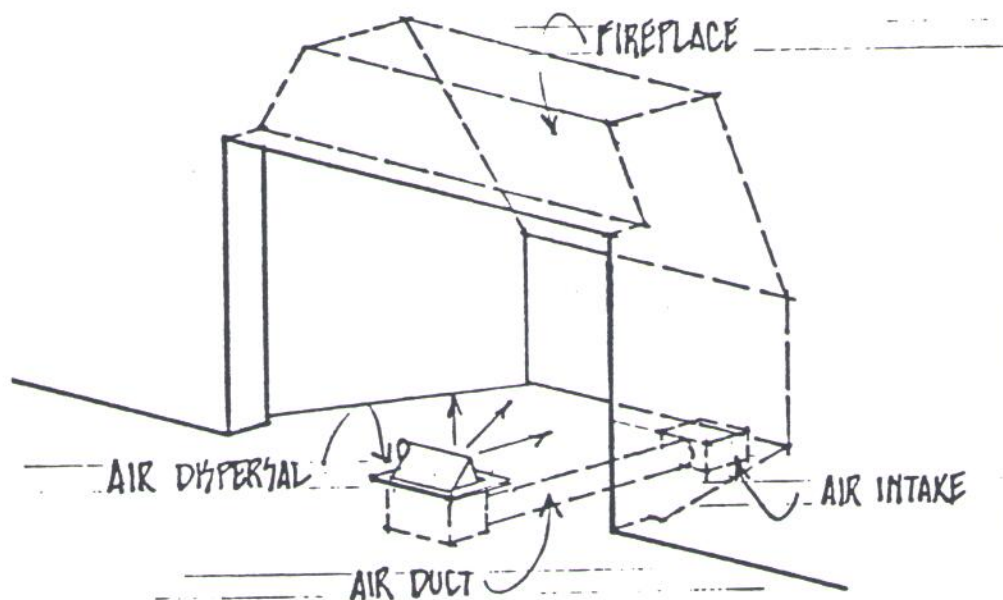

Fig. 5 - Isometric of Exterior Box.



## INSTALLATION

SCALE - NOT

Fig. 6 - Installation of Device Showing  
Position of Connecting Duct.

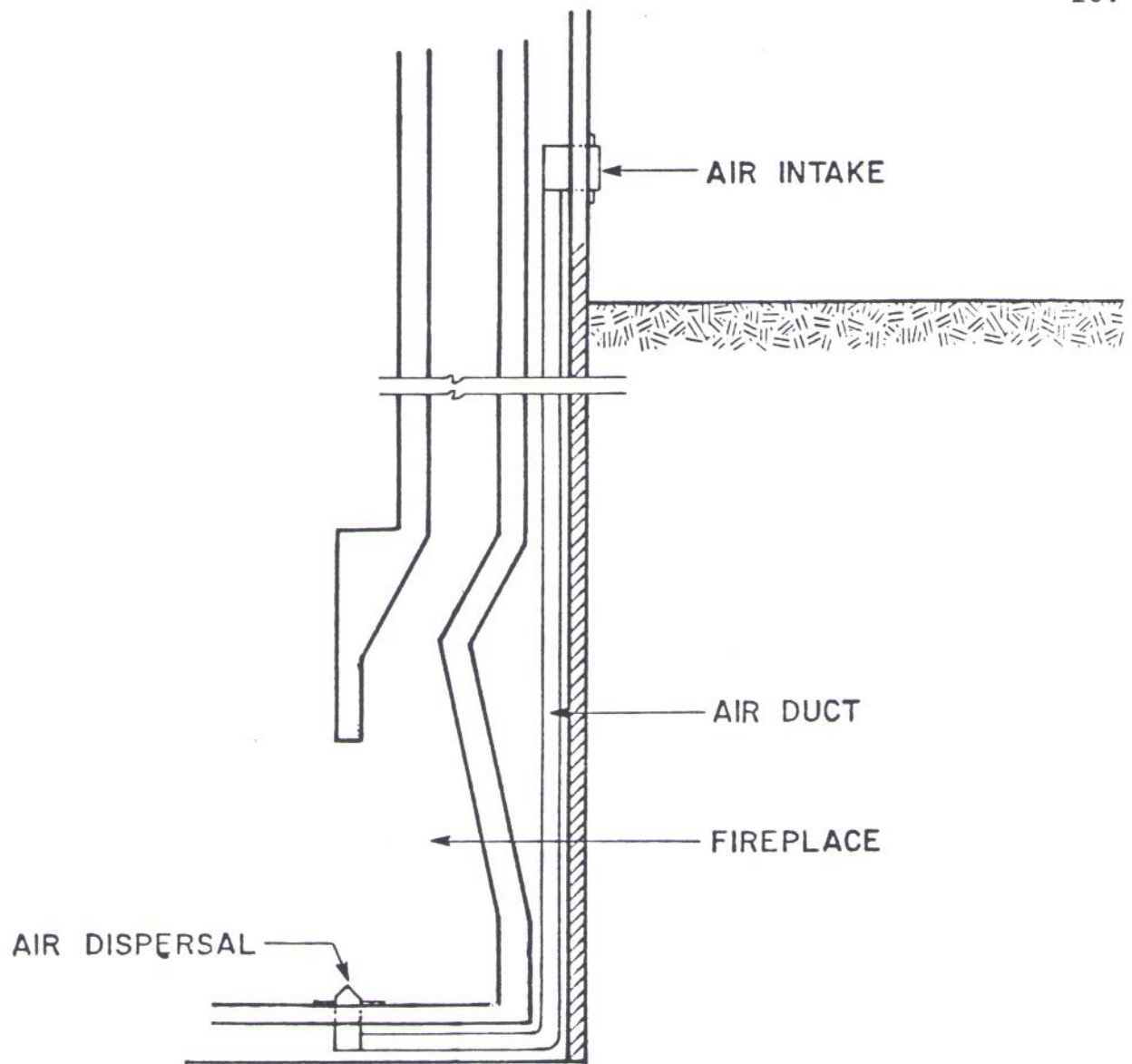

Fig. 7 Basement Installation



Photo 1 - Main Elements of the Fresh Air Intake

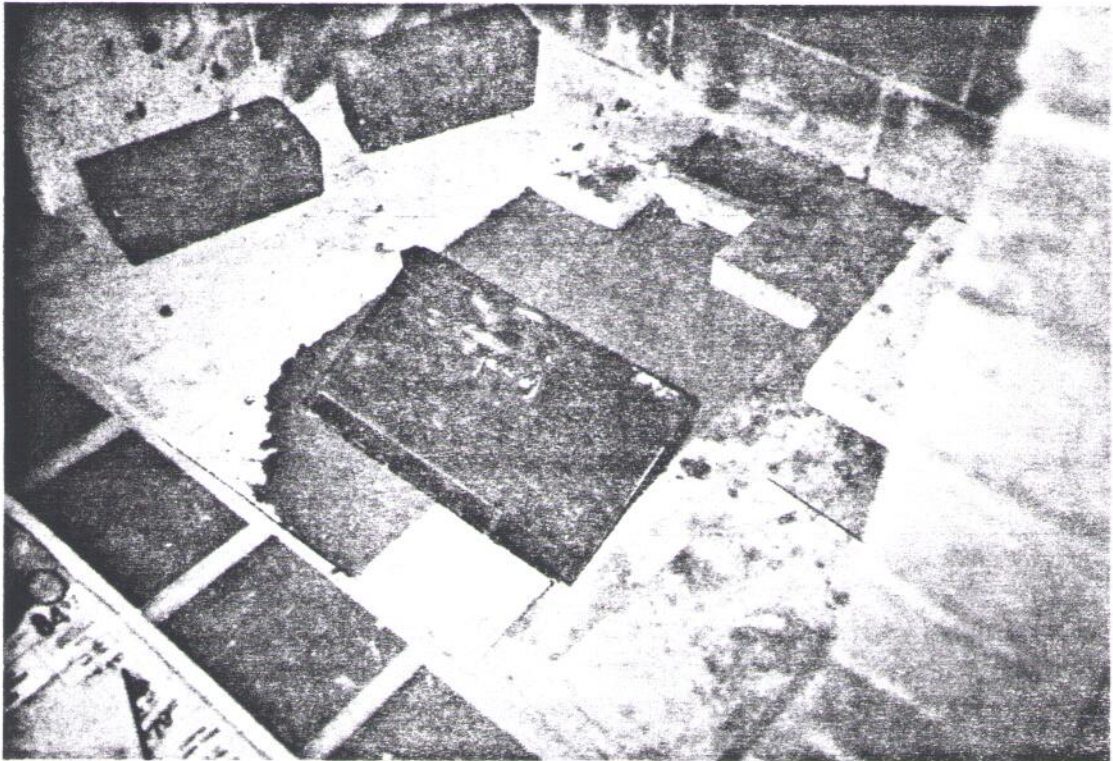

Photo 2 - Interior Outlet Partially Installed.

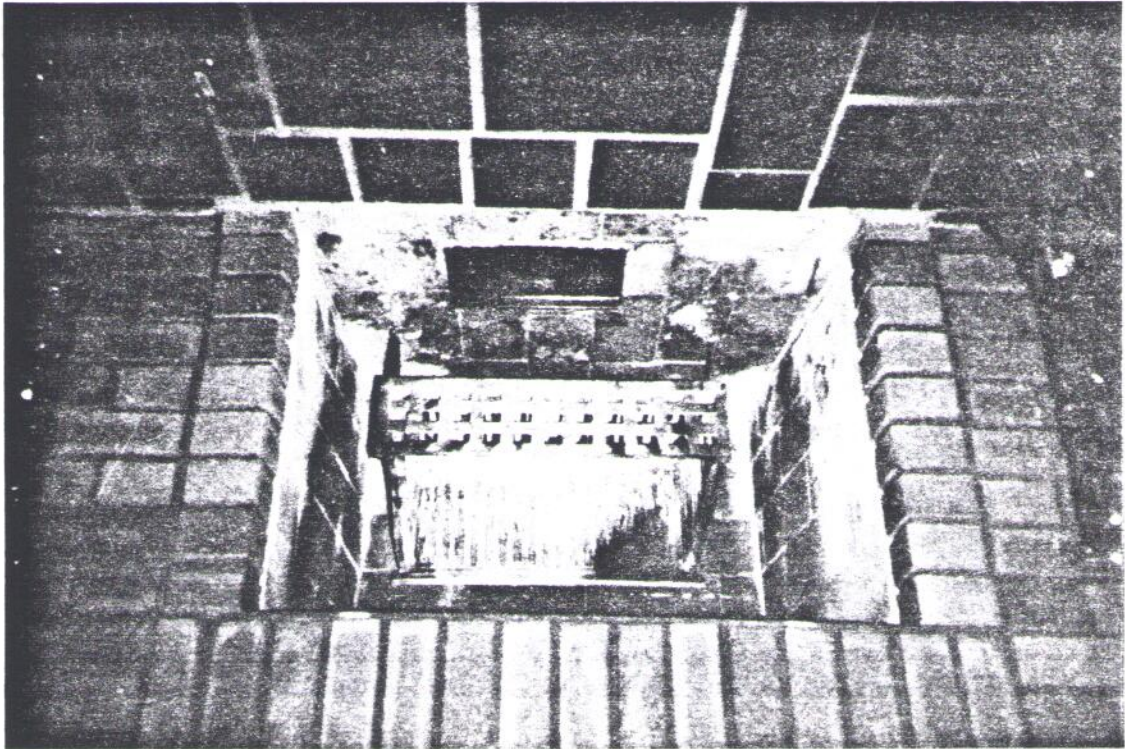

Photo 3 - Finished Interior Installation.

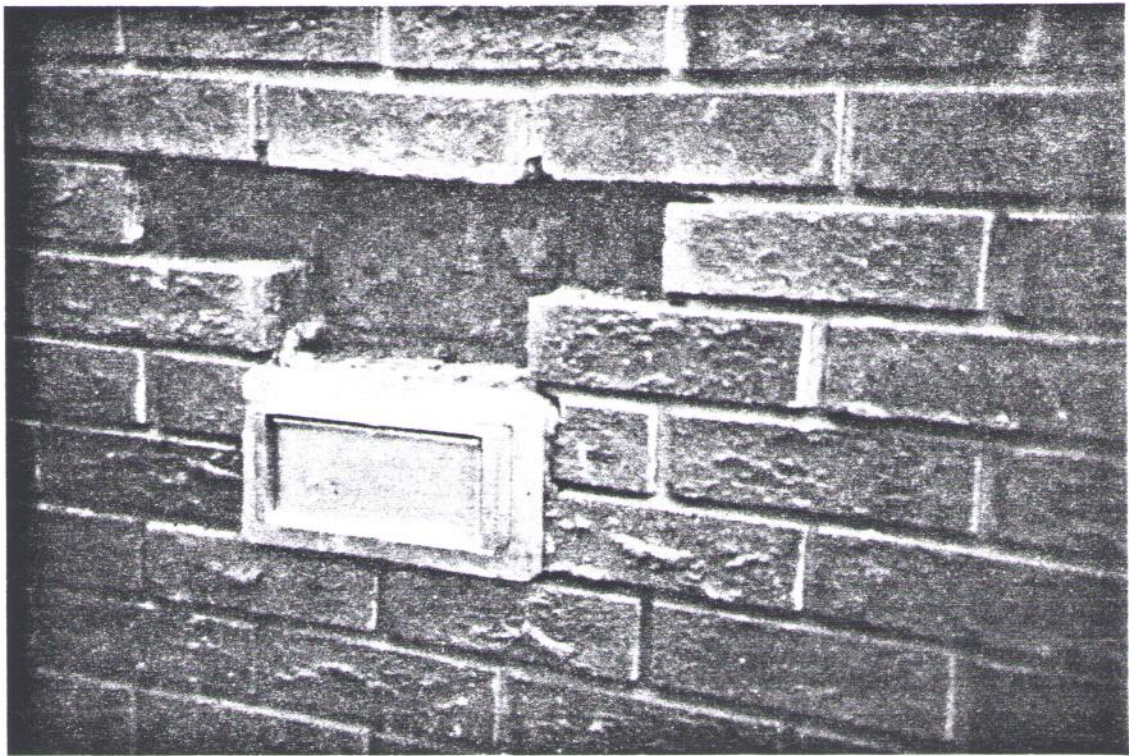

Photo 4 - Exterior Intake Partially Installed.

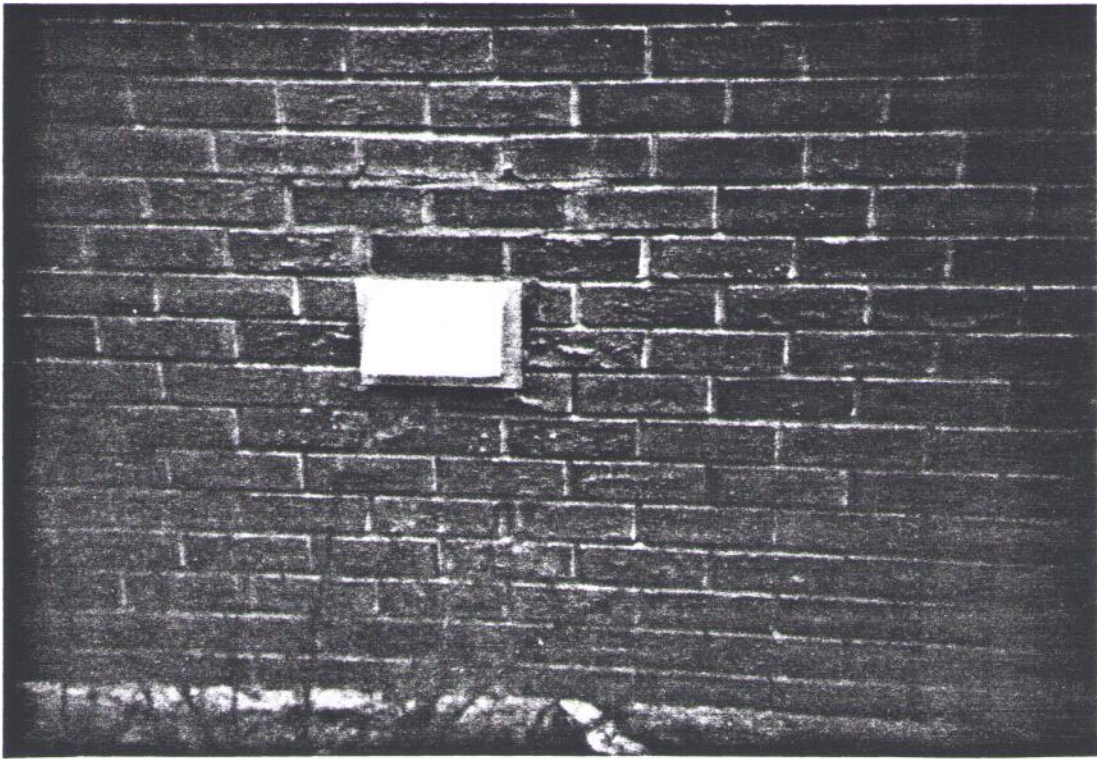

Photo 5 - Finished Exterior Installed.

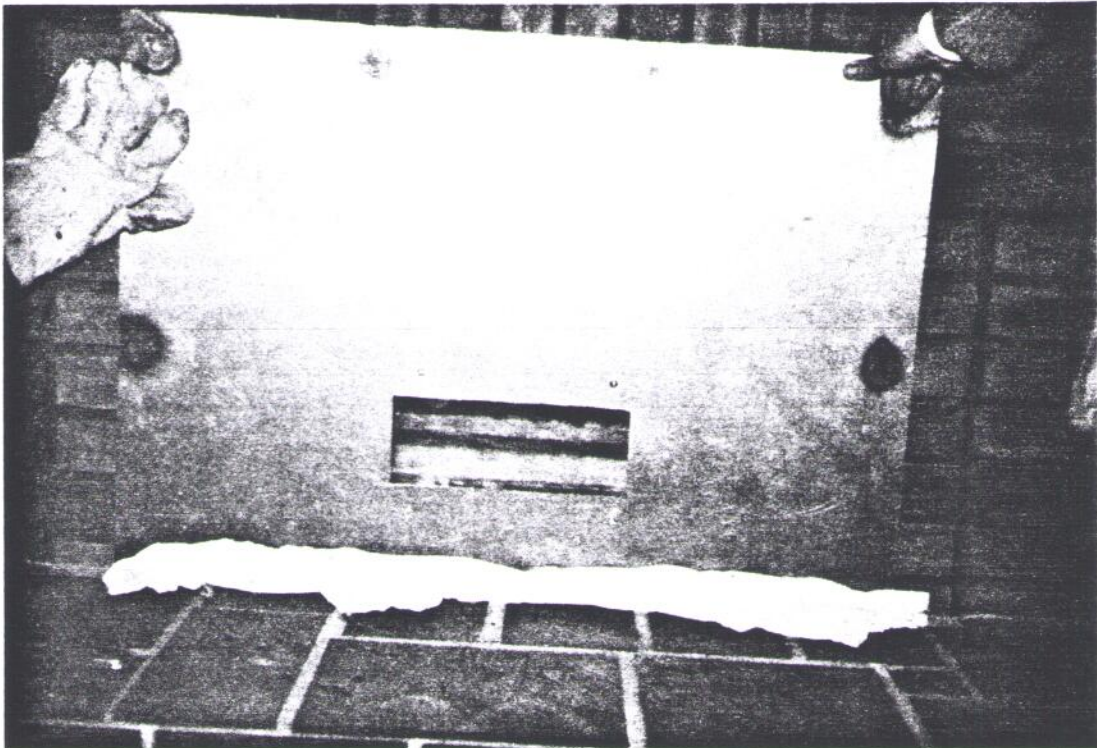

Photo 6 - Metal Closure Provided for Testing.



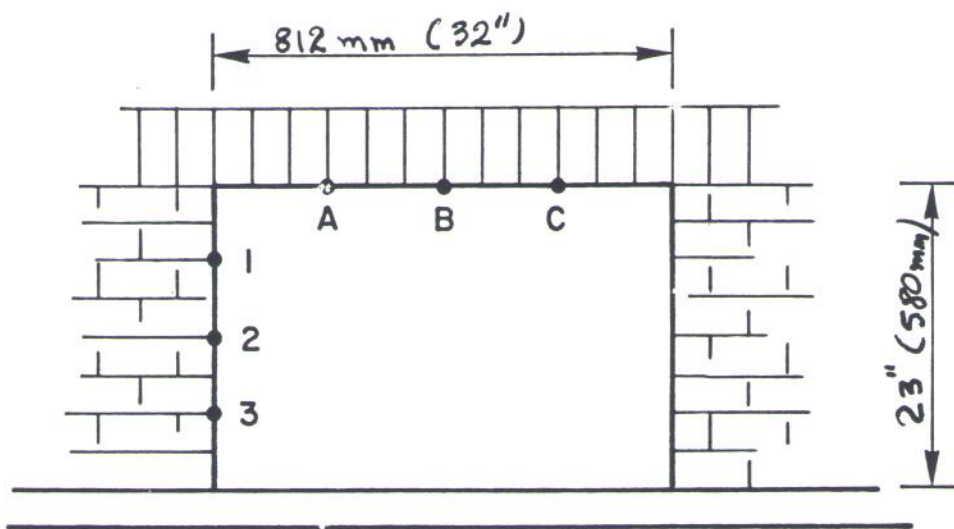

Fig. 8 Locations of Air Flow Measurement

TABLE 1 AIRFLOW MEASUREMENTS

LOCATION	DEVICE CLOSED m/s	DEVICE OPEN m/s	COMMENTS
1	0.254	0.254	an overall
2	0.254	0.254	opening of
3	0.254	0.254	0.055 m <sup>2</sup> was
A	0.254	0.305	provided at
B	0.254	0.279	one window.
C	0.279	0.279	

See Figure 8 - for locations of points where  
flow was measured.

APPENDIX B

TOP MOUNTED FIREPLACE DAMPER

DISTRIBUTORS OF TOP MOUNTED  
CHIMNEY DAMPER

J.F.C. MASONRY SUPPLIES LTD.,  
12805 - 170 Street,  
Edmonton, Alberta.

Telephone: (403) 470-1774

SILVERSTER BUILDING SUPPLIES LTD.,

P.O. BOX 219, STATION T  
CALGARY ALBERTA  
T2H 2G8

PHONE: (403) 243-6031

## MI-CAP

The MI-CAP © 1980 unit was developed by Dr. Michael Hatzinikolas, P. Eng. and Mr. Harry Morstead in an effort to solve these fireplace problems better than other dampers currently available on the market. The device has been tested by the Alberta Research Council in their laboratories and in a number of homes in Edmonton during the coldest part of the winter season. In their report, the Alberta Research Council concluded that:

"IF AIR INFILTRATION OR EXFILTRATION IS OCCURRING THROUGH AN EXISTING CHIMNEY, THIS DEVICE (THE MI-CAP UNIT) SHOULD VIRTUALLY ELIMINATE THIS AIR FLOW."

The residents of the test homes also reported elimination of drafts and increased comfort, as well as elimination of smoking problems.

In the event that your furnace thermostat is near your fireplace, cold air (through transfer or draft) will result in starting your furnace more often than normally required. Thus, resulting in more fuel consumption.

MI-CAP Manufacturing Co. wishes to express sincere gratitude to Dr. Michael Hatzinikolas, and Mr. Harry Morstead for their work in developing the damper and Alberta Housing and Public Works for its support.

## **FIREPLACES HAVE FOUR COMMON PROBLEMS:**

### **PROBLEM!**

1. Air flow from inside the building to the outside, resulting in energy loss.

### **PROBLEM!**

2. Air flow down the chimney and into the enclosed area when the fireplace is not in use, in which case the surrounding area is cooled and uncomfortable, and causes difficulties in lighting the fireplace.

### **PROBLEM!**

3. Cold air currents inside the house caused by air coming in contact with the cold chimney surface.

### **PROBLEM!**

4. Water and snow penetration into the chimney which can cause damage to the joints of the flue liners by freezing and thawing, and deterioration of the fireplace.

Conventional dampers located just above the firebox or glass doors do not deal with these problems adequately.

**MI-CAP © 1980**

**WILL**

