

# *PREFABRICATED MASONRY*

by

M.A. HATZINIKOLAS, Ph.D., P.Eng.<sup>1</sup>  
R. PACHOLOK, M.Sc., P.Eng.<sup>2</sup>

1 Director of Technical Services, Alberta Masonry Institute,  
Edmonton, Alberta

2 Technical Sales Representative, I-XL Industries Ltd.,  
Edmonton, Alberta

**ALBERTA  
MASONRY  
INSTITUTE**



**PREFABRICATED MASONRY**

by

M.A. HATZINIKOLAS, Ph.D., P.Eng.<sup>1</sup>  
R. PACHOLOK, M.Sc., P.Eng.<sup>2</sup>

<sup>1</sup> Director of Technical Services, Alberta Masonry Institute,  
Edmonton, Alberta

<sup>2</sup> Technical Sales Representative, I-XL Industries Ltd.,  
Edmonton, Alberta

## PREFABRICATED MASONRY

by

M. Hatzinikolas<sup>1</sup>, R. Packolok<sup>2</sup>

### INTRODUCTION

Prefabrication of masonry panels has been used successfully in many parts of North America over the years. Even though mason contractors specializing in prefabrication of masonry have completed a number of such projects, this type of construction has not gained wide acceptance. This lack of acceptance by the industry can be attributed to economics and an inadequate understanding of engineering design. Many contractors have found the cost of prefabrication of panels and subsequent transportation and erection to be higher than on-site construction. Although this may hold true for straight simple walls, in cases where unusual architectural features require expensive backup systems, where special attention must be paid to joints and units, or where large numbers of repeated elements occur, prefabrication can be shown to be competitive. Also, for Canada and northern United States, the masonry work can be carried out in the shop during winter with the costs of

---

<sup>1</sup> Director of Technical Services, Alberta Masonry Institute, Edmonton, Alberta.

<sup>2</sup> Technical Sales Representative, I-XL Industries Ltd., Edmonton, Alberta.

prefabrication and erection being offset by savings in heating and hoarding, as well as the added advantage of keeping masons employed year round.

Although acknowledging that cost is of paramount importance, this paper places emphasis on the engineering design aspects of prefabrication and also examines the stresses and strains that occur during transportation and erection of panelized masonry. The principles discussed in this paper were utilized in the design of a seven storey semi-cylindrical arch which was constructed in Edmonton, Alberta. Design examples which demonstrate the engineering analysis involved in preconstructed masonry are also presented.

## **DESIGN CONSIDERATIONS**

### **A. General**

For the purpose of this paper, two types of panels will be investigated: panels which resist all applied loads by internal stresses and reactions, and panels which rely on back-up systems, such as light steel frames, to transfer the applied loads to the main frame. Figure 1 shows a "pure" masonry panel, and Figure 2 shows a panel utilizing a light frame to increase its stiffness and carry superimposed loads. The panel shown in Figure 1 relies on light steel reinforcement placed in the masonry to resist bending and other stresses resulting from service, handling and erection loads. All loads acting on the brick panel shown in Figure 2 are transferred to the back-up frame, which is attached

to the masonry by means of metal ties, which in turn are fastened to light steel reinforcement incorporated in the masonry units.

The properties of the masonry units, mortar and steel reinforcement used in the examples discussed in this paper are those of standard construction materials and units. All examples utilize Type S mortar, mixed in proportions by volume as follows: 1 part normal portland cement,  $\frac{1}{2}$  part lime and  $4 \frac{1}{2}$  parts masonry sand. No additives are incorporated in the mortar to increase the tensile and/or shear bond strength. The masonry units are burned clay units conforming to CSA Standard A82.1-M1977 "Burned Clay Brick<sup>1</sup>". The allowable stresses for design are those specified in Table 6 of CSA Standard CAN3-S304-M78, "Masonry Design and Construction For Buildings<sup>2</sup>", namely  $0.4 f'_m$  in flexural compression,  $0.06 \sqrt{f'_m}$  but not to exceed 0.35 MPa in shear,  $0.25 f'_m$  in bearing and a modulus of elasticity of  $1000 f'_m$  but not to exceed 20,000 MPa. The yield strength of the steel reinforcement is assumed to be 400 MPa for bar reinforcement, and 500 MPa for joint reinforcement. The allowable tensile stress in the reinforcement is then 165 MPa and 200 MPa, respectively. A modulus of elasticity of 200,000 MPa is used for both types of steel reinforcement.

The design formulae used in the examples are presented in Appendix A.

## **B. Design Examples**

### **1. Pure Masonry Panels**

#### **(i) Straight Wall Panel Design**

The pure masonry panel shown in Figure 1 is to be designed as an element of a sound barrier wall to form the configuration shown in Figure 3. The design requires a wall height of 2400 mm, capable of withstanding a wind load of 1.2 KPa by spanning horizontally between pilasters spaced at 3000 mm on centre. The wall panel is constructed of 100 mm nominal width burned clay units producing a panel weight of  $1.40 \text{ KN/m}^2$ , which corresponds to every second void being grouted. Handling conditions warrant an impact load factor of 2.0 for the panel in a vertical position, and an impact factor of 1.25 for a panel tilt of 15 degrees. The panels must be designed to satisfy each handling condition in both the construction orientation, with the units laid in standard running bond to allow for grouting, and in the installation orientation, with the panel rotated 90 degrees so that the main reinforcing bars are horizontal.

#### **Loading Case 1 - Service Loads**

##### **a. Wind Load**

The panel must be designed to carry a horizontal wind load of 1.2 KPa in its installation orientation. Assuming that the main reinforcing bars are in the centre of the panel thickness, an effective depth of one half of the wall thickness, or 45 mm, will be used in the flexural design. The maximum moment that can be resisted by the masonry is 2.70 kN-m, which is greater than

the maximum applied moment of 2.62 kN-m. A steel reinforcement area of 418 mm<sup>2</sup> is required to resist the applied moment, and therefore 5-10M bars giving an area of 500 mm<sup>2</sup> is specified.

The maximum shear force that can be resisted by the masonry panel, without utilizing shear reinforcing, is 17.1 kN, which is greater than the maximum applied shear force of 3.9 kN.

The bearing force from each panel end onto its supporting pilaster is 3.9 kN. Although theoretically this requires a minimum bearing length of 0.72 mm, a bearing length of 25 mm will be specified.

**b. Dead Load**

The panel must be designed to carry its own dead load of 1.4 kN/m<sup>2</sup> in the installation orientation. Assuming that only the reinforcing bar in the bottom core is effective in resisting flexure, an effective depth of 2300 mm (wall height minus 100 mm) is used in all flexural calculations. The maximum moment that can be resisted by the masonry is 273.0 kN-m, which is much greater than the maximum applied moment of 3.1 kN-m. An area of steel reinforcing equal of 9 mm<sup>2</sup> is required to resist the applied moment. Therefore, place 1-10M reinforcing bar in the bottom core of the panel.

The maximum shear force that the masonry can resist without the addition of shear reinforcing is 33.0 kN, which is greater than the maximum applied shear load of 4.5 kN.

The required length of bearing on the pile or pile cap is 22.4 mm for the bearing load of 4.5 kN. Therefore, use a minimum

bearing length of 25 mm.

### **Loading Case 2 - Handling Loads - Vertical Position**

An impact factor of 2.0 is used for the design of the panel in a vertical position:

#### **a. Construction Orientation**

Assuming lifting by means of the outside reinforcing bar at each end of the panel, 2-10M bars providing an area of  $200 \text{ mm}^2$  will satisfy the requirements. The maximum load that can be carried by this reinforcement is 33.0 kN, which is greater than the factored applied load of 18.2 kN.

Flexural loads are resisted by No. 9 gauge (3.66 mm diameter) ladder type joint reinforcing spaced at 400 mm on centre, starting from the second mortar joint at each end. Assuming only the bottom two layers of joint reinforcing are effective results in an effective depth of 2000 mm. The allowable moments that can be resisted by the masonry and the reinforcing steel are 168 kN-m and 15 kN-m, respectively, both of which are greater than the maximum applied moment of 5.4 kN-m. The allowable shear force that the masonry can resist is 29.9 kN which is greater than the maximum applied shear force of 9.1 kN.

#### **b. Installation Orientation**

As previously indicated in the construction orientation, 2-10M lifting bars are provided, one at each end of the panel. The applied flexural loads are two times those used in Loading



Case 1 - Dead Loads. The allowable masonry moment of 273 kN-m is greater than the maximum applied moment of 6.1 kN-m. An area of reinforcing steel equal to  $18 \text{ mm}^2$  is required, and therefore the 1-10M (or 100  $\text{mm}^2$ ) previously added is adequate.

The allowable masonry shear load of 33 kN is greater than the maximum applied load of 9.1 kN.

### **Loading Case 3 - Handling Loads - 15 Degree Tilt**

An impact load factor of 1.25 is used for the design of the panel with a tilt of 15 degrees.

#### **a. Construction Orientation**

The factored dead load of the panel is  $0.45 \text{ kN/m}^2$  which is less than the wind load of  $1.2 \text{ kN/m}^2$  for which the panel has been previously designed.

#### **b. Installation Orientation**

No 9 gauge ladder type joint reinforcing at 400 mm on centre had already been chosen. Providing tooled mortar joints and 15 mm cover to each strand yields an effective depth of 75 mm.

The allowable masonry and steel reinforcing moments are 7.08 kN-m and 0.96 kN-m respectively, which are greater than the maximum applied moment of 0.86 kN-m. The allowable masonry shear force of 33 kN is greater than the maximum applied shear force of 1.5 kN.

Figure 1 summarizes the sound barrier wall panel design and shows the required reinforcement and placement.

Panels similar to the one discussed can be constructed with large masonry units such as concrete blocks or giant bricks, and utilized for the construction of residential and commercial structures both as load bearing wall systems or as infill panels or cladding.

**(ii) Shelf Angle Cover**

The aesthetic appearance of the shelf angle support for brick veneer can be enhanced by the addition of a rowlock or soldier course of brick below the steel angle. Details of soldier coursing and rowlock coursing shelf angle coverings are illustrated in Figures 4 and 5, respectively. Photos 1 and 2 show one of the many successful applications of this technique using a rowlock brick course.

This additional covering course can be prefabricated, then lifted into place and mechanically fastened to the shelf angle. This eliminates the need for temporary support of the brick course while the mortar sets. The length of each individual prefabricated segment can vary depending on the capacity of the hoisting apparatus available at the job site. This type of detail may also be utilized in small sized panels which can be handled by two men. The joint formed at the junction of two segments can be filled with mortar if a solid joint is required, or with styrofoam road and caulking if a vertical control joint is required.

The structural requirement of this detail are achieved by the attacking anchors to the shelf angle. These anchor bolts,

which are installed in the mortar joints during prefabrication, are hooked around reinforcing bars located in the brick cores. The brick cores containing reinforcing bars should be completely filled with mortar or grout to prevent slippage and to ensure predictable behaviour. The ability of small panels to resist flexure in this type of application has been experimentally confirmed as part of a requirement for the acceptance of the system in a recent project located in Edmonton, Alberta. The segments were constructed of Type S mortar and typical pressed clay brick manufactured by I-XL Industries Ltd. The brick has a three hold configuration with the diameter of each hold being approximately 38 mm. Based on the unit strength of 35 MPa, the 28 day design compressive strength is 11.60 MPa in accordance with Reference 2. All three cores are filled solid with mortar, with 1-10M reinforcing bar (Grade 400) in each of the outside cores. The segments were tested after seven days by applying a line load at centre span. The test specimens were supported by concrete pedestals under the last two bricks at each end. The clear span was 747 mm for the soldier course specimen, and 546 mm for the rowlock course specimen. The ultimate loads were 41.4 kN for the soldier course specimen and 28.0 kN for the rowlock course specimen.

#### **Specimen 1 - Soldier Coursing**

Based on Figure 4 and neglecting the top bar, the following design values are obtained. The moment capacity of the section is 3.03 kN-m based on the masonry, and 4.98 kN-m based on the

reinforcing steel. These moment values are derived from a masonry stress of 11.60 MPa and a steel stress of 400 MPa. Based on the capacity of the masonry, the corresponding mid-span load on the specimen is 16.2 kN. However, the test value was 41.4 kN, or 2.6 time the calculated value. For design, Reference 2 specifies the allowable masonry and steel reinforcement stresses as 0.4 times the ultimate stresses. Thus, after only 7 days the actual factor of safety for this segment was  $2.6/0.4 = 6.5$ .

### **Specimen 2 - Rowlock Coursing**

Referring to Figure 5, the effective depth is 45 mm and the area of reinforcement (2-10M) is  $200 \text{ mm}^2$ . The allowable masonry moment capacity is 0.66 kN-m, and the allowable reinforcing steel moment capacity is 3.2 kN-m. Based on ultimated stresses, the capacity of the masonry is exceeded when a concentrated load of 4.84 kN is applied at mid span. The test value obtained at 7 days was 28.0 kN, or 5.8 times the calculated value, which results in a factor of safety of  $5.8/0.4 = 14.5$ .

From the preceeding calculations and the results obtained from the testing of these elements, it is quite apparent that the factors of safety involved in the design of prefabricated shelf angle covering segments are quite large. The test results indicated that this type of application provides a very successful architectural detail. Because of the stocky configuration and considerable over-design of the shelf angle cover segments, handling stresses will not usually present any problems.

**(iii) Soffits**

Prefabrication is advantageous where the masonry element is in a horizontal plane, with the underside of the element being the finished face. This situation occurs with soffits such as the one in the interior of a structure currently being designed for Edmonton and illustrated in Figure 6. In this instance the brick soffit panel will be constructed on the ground level in a vertical position and, upon curing, will be rotated into a horizontal orientation, raised into place and fastened to the structural back-up frame or suspended from the ceiling. The design of such a panel must account for service loads that will be applied and also handling and erection stresses. The design procedures to be followed are similar to those for the sound barrier wall panel previously designed and will therefore not be repeated.

For handling, the location of load points as well as the magnitude of load at each location will depend upon the means of moving and transporting the panel, and will no doubt vary as individual contractors will have preferred methods for constructing and installing the panel. In some cases the rear of the panel may not be accessible for fastening to the frame. In these cases, mechanical fastening can be achieved by initially omitting brick at critical locations to allow for fastening, and then inserting these bricks at a later point in time.

## **2. Panels With Steel Frame Back-up**

### **(i) General**

Prefabricated panels with back-up steel frames are identical to "pure" masonry panels once both have been installed. The difference between the two occurs during the handling, transportation and erection phases of construction. Whereas "pure" masonry panels must internally resist all applied loads until installed, masonry panels with steel back-up frames rely on the steel frames to help resist erection and handling loads. The following examples deal only with the structural adequacy of the masonry in resisting handling and service loads and do not emphasize the design of the steel back-up frame.

### **(ii) Straight Wall Panel Design**

A typical prefabricated straight wall panel, such as that proposed for a structure in St. Albert, Alberta is examined in this section. As illustrated in Figure 2, this panel is to be constructed and installed with two vertical steel legs providing support for the masonry. The masonry must span horizontally across these supports.

The design of the brick masonry is governed by the location of the steel legs and the design loads on the panel. The overall appearance of the structure utilizing this system is shown in Figure 7.

Handling conditions are a function of the contractor's methods of construction. For this example the following load cases are considered.

Loading Case 1 - Service Loads

Loading Case 2 - Handling Loads - Vertical Position - Impact  
Factor = 2.0

Loading Case 3 - Handling Loads - 15 Degrees Tilt - Impact  
Factor = 1.25

The brick used in this example is a 100 mm nominal width unit with a design compressive strength,  $f'm$ , of 10.0 MPa. The panel dimensions are 1840 mm in height and 3000 mm in length.

The panels in the structure shown in Figure 7 incorporate a steel angle to provide support for the dead load of the brick panel. The following design example assumes this angle is not present in the panel assembly. The provision of a support angle will result in a decrease in the tie design requirements as well as added stability to the assembly.

#### **Loading Case 1 - Service Loads**

An overhang dimension of 0.207 times the overall panel length results in the most economical design since the maximum negative moment equals the maximum positive moment when the overhang equals  $0.207 L = 620$  mm. For this example the overhang shall be 600 mm.

#### **(i) Wind Load**

The panel must resist a horizontal positive wind load of 0.63 kPa on the windward side of the building or a suction of 0.45 kPa on the leeward side. Assume No.9 gauge (3.66 mm diameter) ladder type joint reinforcing steel with 15 mm cover

from the face of the brick, giving an effective depth of 75 mm. The masonry moment capacity is 2.91 kN-m/m, which is greater than the applied moment of 0.14 kN-m/m. An area of reinforcing steel of  $10.3 \text{ mm}^2/\text{m}$  is required, which corresponds to a spacing of 1020 mm. Let the actual joint reinforcing spacing equal 400 mm. The allowable masonry shear force of 12.9 kN/m is greater than the maximum applied shear force of 0.57 kN/m. The applied suction load of 2.5 kN per panel requires a minimum of 2 No. 9 gauge ties per panel.

**(ii) Dead Load**

The service dead loads are one-half of Case 2 - Handling Loads with the panel in a vertical position and an impact factor of 2.0. Therefore, Case 2 governs.

**Loading Case 2 - Handling Loads - Vertical Position**

An impact factor of 2.0 is applied to the panel dead load of  $1.9 \text{ kN/m}^2$ . Assume only the bottom two layers of joint reinforcing are effective in flexure; i.e. the effective depth =  $1840 - 330 \text{ mm} = 1510 \text{ mm}$ . The allowable masonry moment of 106 kN-m and the allowable reinforcing steel moment of 11.5 kN-m, are both greater than the maximum applied moment of 1.56 kN-m. The allowable masonry shear force of 23 kN is greater than the maximum applied shear force of 6.3 kN.

The ties connecting the masonry to each support leg of the back-up frame must resist a vertical shearing force of 105 kN. This load requires a minimum tie area of  $88 \text{ mm}^2$  per leg.



Assuming a tie at each layer of joint reinforcing, i.e. 6 ties per support leg, the area per tie must be a minimum of  $15 \text{ mm}^2$ .

### **Loading Case 3 - Handling Loads - 15 Degree Tilt**

An impact factor of 1.25 is applied to the panel dead load giving a factored dead load of  $0.61 \text{ kN/m}^2$ . The wind load of  $0.63 \text{ kN/m}^2$  in Case 1 is more severe and therefore governs in terms of flexural considerations. The ties may be subjected to tension depending on which direction the panel is tilted. This tension force requires that each of the 12 ties have a minimum area equal to  $1.4 \text{ mm}^2$ .

### **Design Summary**

1. Provide No. 9 gauge ladder type joint reinforcing at 400 mm on centre, starting from the second course from the bottom of the panel. Provide reinforcing in the second joint from the top of the panel.
2. Provide a minimum of 6 ties per support leg with each tie having an area of steel greater than or equal to  $15 \text{ mm}^2$ . Ties must be installed in such a way that they act in shear and/or tension, and not in bending.
3. A light steel angle may be provided along the bottom edge of the panel and fastened to the vertical steel legs of the back-up frame. This would provide vertical support to the

panel and assure that no individual bricks could break away from the panel. The number or area of required ties would then be decreased. Six No. 9 gauge ties per support leg would be adequate.

The straight wall panel designed above utilizes only two steel members for horizontal and vertical support of the brick. Assuming that job-site lifting devices are adequate, the length of straight wall panels can be increased by the addition of other vertical support legs in the back-up frame. The spacing of the vertical support legs will control the required reinforcement in the masonry. The steel back-up frame can also be designed to provide both lateral and vertical support to the windows which will be installed between each row of prefabricated brick panels.

The prefabricated panel shown in Figure 8 has been designed to support the window loads as well as the masonry loads. The lateral wind loads on the brick are resisted by the back-up frame which consists of a combination of steel angles and metal studs. The steel angles provide the structural integrity of the frame, while the metal studs merely serve as infills between these angles.

### **(iii) Panels With Sills, Lintels and Soffits**

The principles used in the design of the preceding straight wall panel can be applied in the design of more complex prefabricated panels such as those shown in Figures 9 to 13. These panels consist of either a horizontal or sloped sill

combined with a vertical lintel portion and a horizontal soffit.

Although each panel differs from the others, the design principles are the same. The brick masonry must be designed to transfer the service and handling loads to the steel back-up frame. The size of the steel frame members needed to satisfy handling and erection requirements may possibly be reduced if the masonry and steel frame are designed to act compositely.

**(iv) Semi-cylindrical Arch**

Prefabricated panels with a steel frame back-up can be employed to produce interesting and unusual architectural features that may not be possible using conventional laid-in-place methods. Such was the case for a seven storey semi-cylindrical arch designed and constructed in Edmonton, Alberta. As illustrated in Figures 14 to 18 and Photos 3 to 11, the arch consists of two semi-cylindrical portions 2400 mm in diameter, rising vertically for 16.81 meters, and then curving together at the top to form an arch with an inside diameter of 6000 mm. All the bricks in the doubly curved portion of the arch were individually cut to provide continuous and symmetrical mortar joint lines.

The steel back-up frame was designed to resist all handling and service loads, as the design based on composite action between the masonry and steel frame proved too complex. The arch was constructed in the mason contractor's shop in floor height segments. Each semi-cylindrical segment was designed and constructed so that the segment could be vertically divided into

two equal portions. The reasons for vertically dividing each segment was two-fold: the smaller portions increased the ease of handling and erection and the installation of a glass wall, which divided the semi-cylindrical segments into a warm side and a cold side was facilitated, thus providing a thermal break in the brick veneer. The sequence of individual panel construction accounted for continuity of the running bond pattern across all panel to panel interfaces. The bottom panel of one leg of the arch was constructed first, followed by its adjoining panel, then the next adjoining panel, and so on, with the bottom panel of the other leg being constructed last. Provisions for attaching the prefabricated panels were made during construction of the concrete frame of the structure. The panels were trucked to the job site, hoisted into place and mechanically fastened to the structure to provide a most unique and interesting architectural detail.

#### **SUMMARY AND CONCLUSIONS**

The examples designed and discussed in the preceding pages are by no means the only building elements that can be prefabricated. They only serve to present principles involved in the design of prefabricated masonry, with the hope of stimulating greater use of, as well as new ideas for, prefabricated masonry. Although the magnitude and location of handling loads will vary with the preferred erection methods of the individual mason contractor, the preceding design examples have illustrated that typical handling requirements can be adequately satisfied.

## **ACKNOWLEDGEMENTS**

Information in this report has been obtained from various sources and the authors wish to express their sincere appreciation for the contributions of a number of firms and individuals.

A number of design details in this paper have been successfully employed by architects in the Edmonton, Alberta area. The contributions of the firms of Chandler Kennedy, Holland-Cummins, Peter Hemmingway and Douglas Cardinal are gratefully acknowledged. Details were also provided by Vet-O-Vitz Masonry Systems of Brunswick, Ohio.

The structural consulting group of Mid-Canada Consultants, particularly Mr. M. Rosseker, P.Eng., and Mr. B. Parkinson contributed significantly in the design of the cylindrical arch discussed in this paper. Construction of the cylindrical arch was carried out by Bastian Masonry of Edmonton. Egon Bastian provided valuable contributions in establishing fabrication and erection procedures. Prof. J. Longworth of the Civil Engineering Department of the University of Alberta reviewed the manuscript.

**REFERENCES**

1. CSA Standard A82.1-M1977. "Burned Clay Brick", Canadian Standards Association, Rexdale, Ontario, Canada, June, 1977.
  
2. CSA CAN3-S304-M78. "Masonry Design and Construction for Buildings", Canadian Standards Association, Rexdale, Ontario, Canada, April, 1978.

APPENDIX A - DESIGN FORMULAE

Reinforced Brick Masonry Flexural Design Formulae:

$$n = \frac{E_s}{E_m}$$

$$k = \frac{1}{1 + \left(\frac{f_s}{n \cdot f_m}\right)}$$

$$j = 1 - \frac{k}{3}$$

$$M_m = \frac{f_m \cdot j \cdot k \cdot b \cdot d^2}{2}$$

$$M_s = A_s \cdot f_s \cdot j \cdot d$$

$$V_m = v_m \cdot b \cdot j \cdot d$$

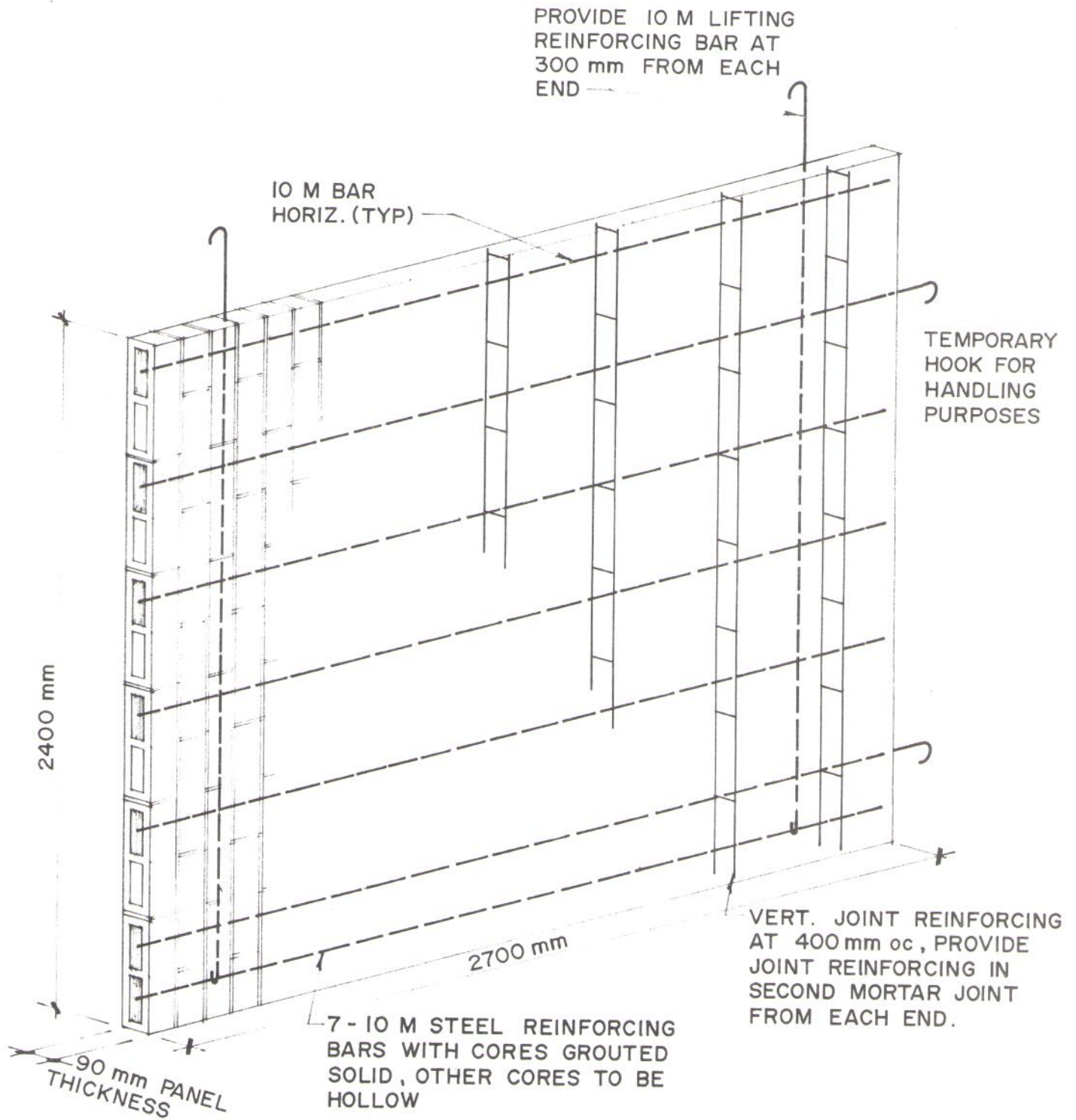
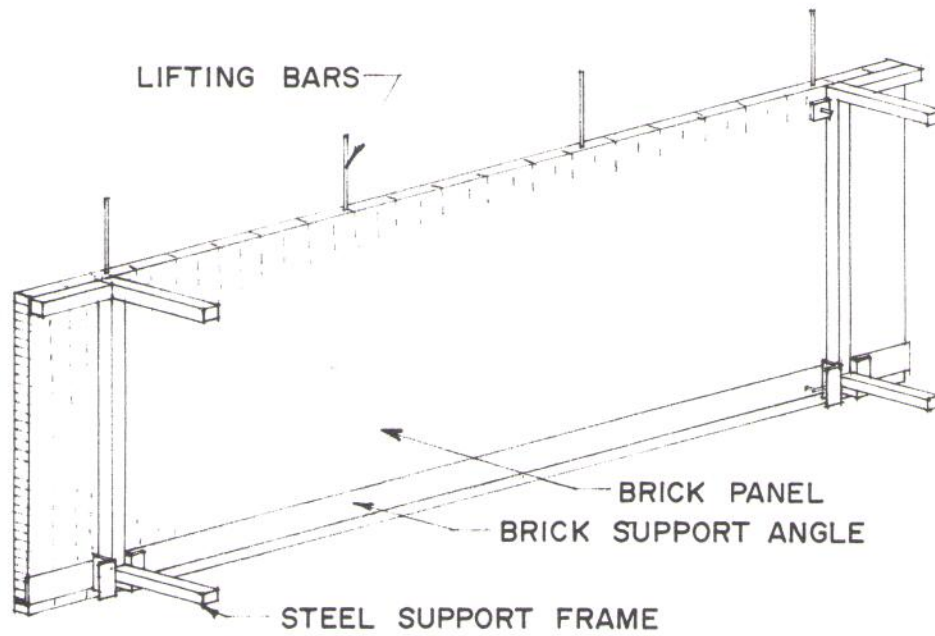

Figure 1: "Pure" Masonry Sound Barrier Wall Panel





## ST. ALBERT PROVINCIAL BUILDING

Figure 2: Masonry Panel with Steel Back-up Frame

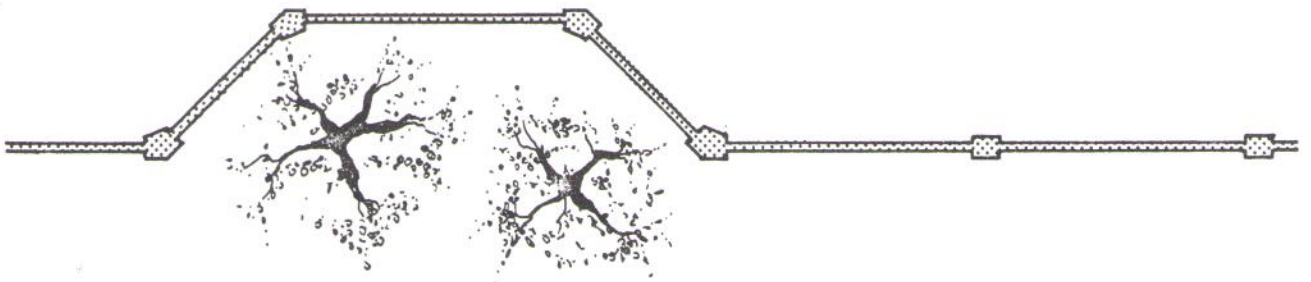
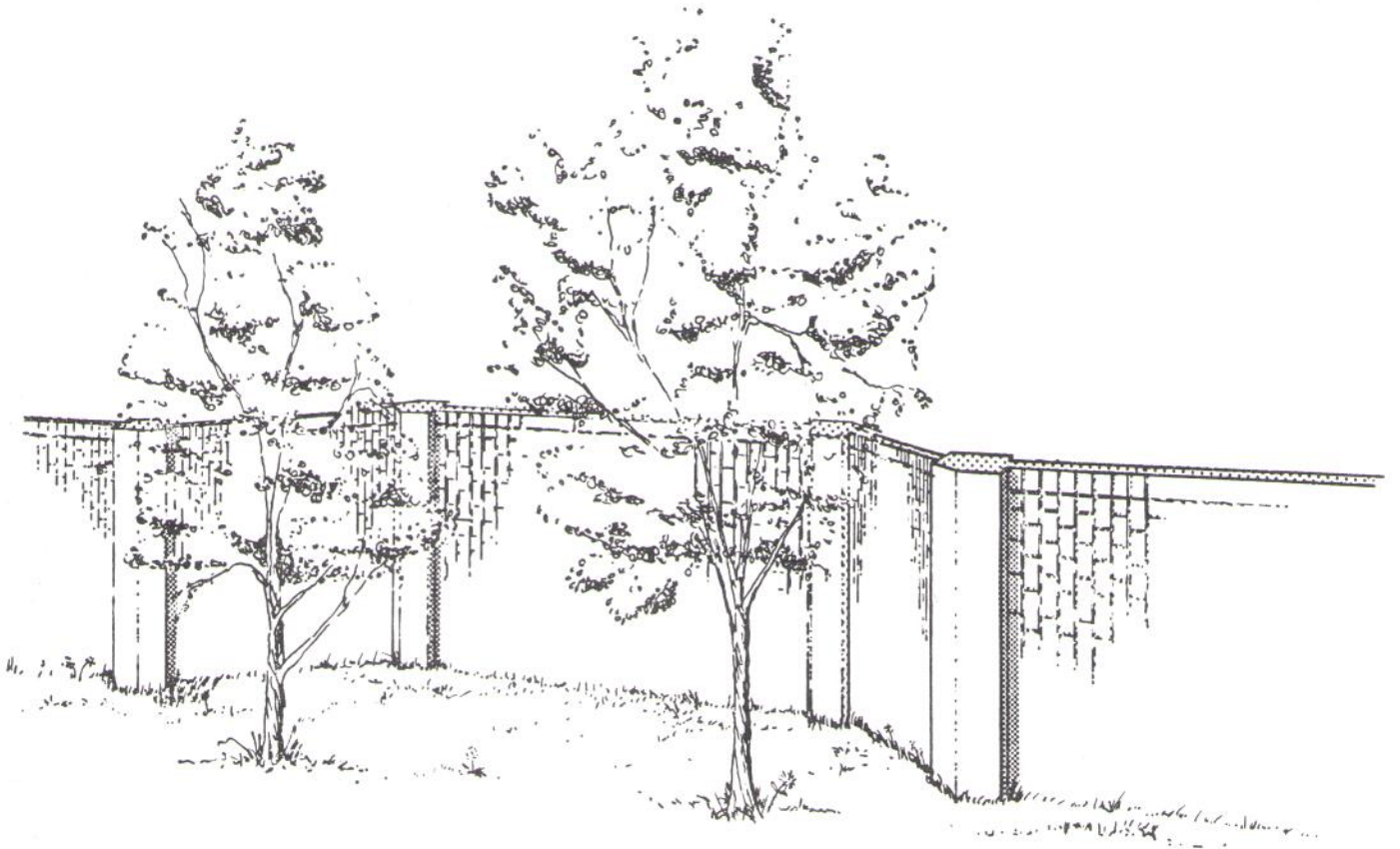
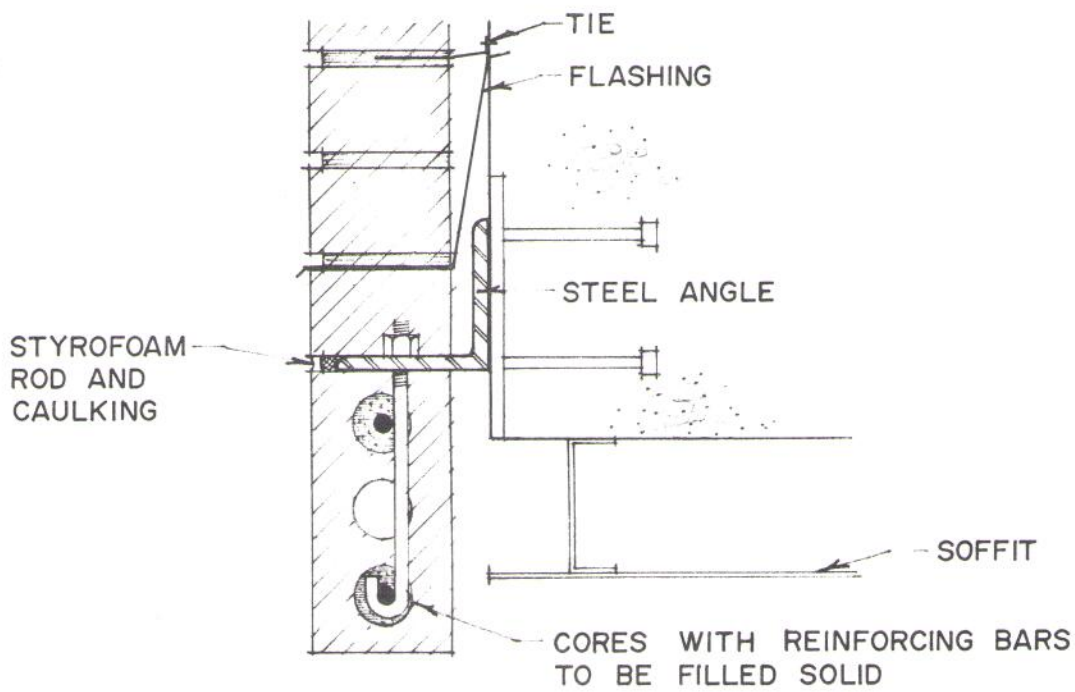
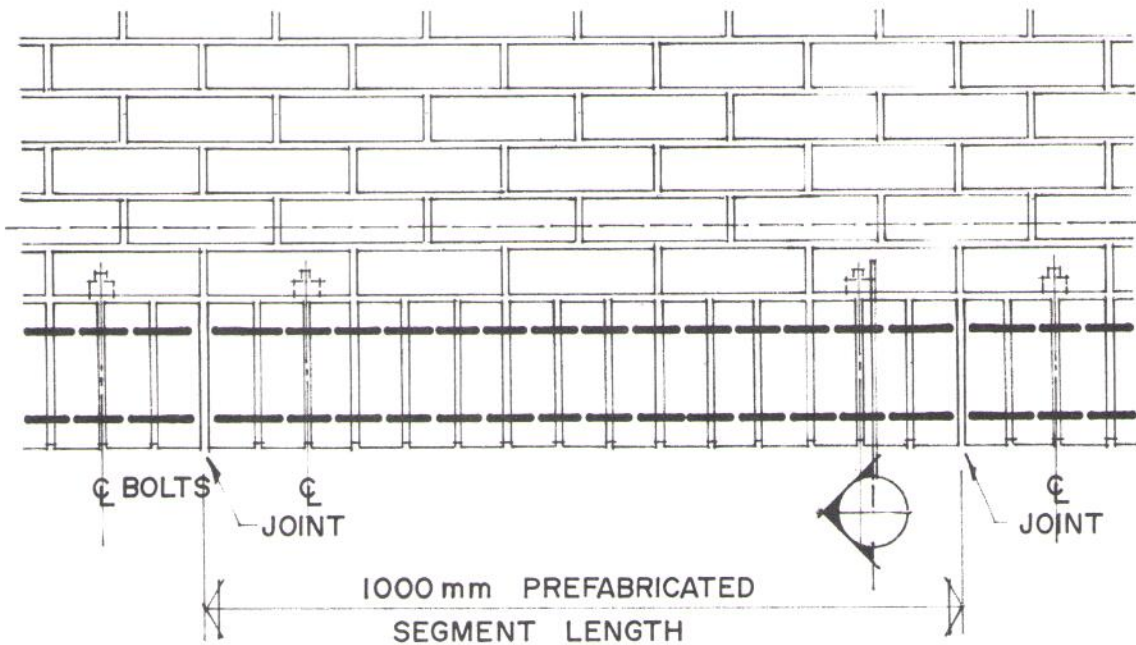
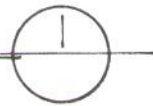

Figure 3: Masonry Sound Barrier Wall



## SECTION



## ELEVATION

Figure 4: Brick Soldier Course Shelf Angle Cover

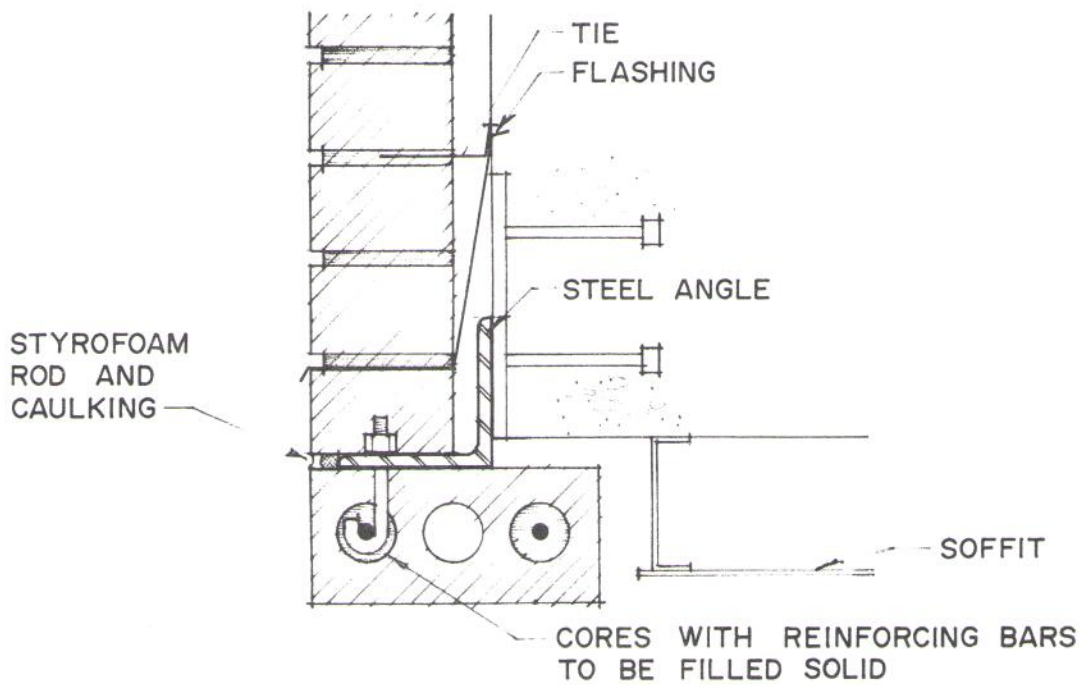

## SECTION

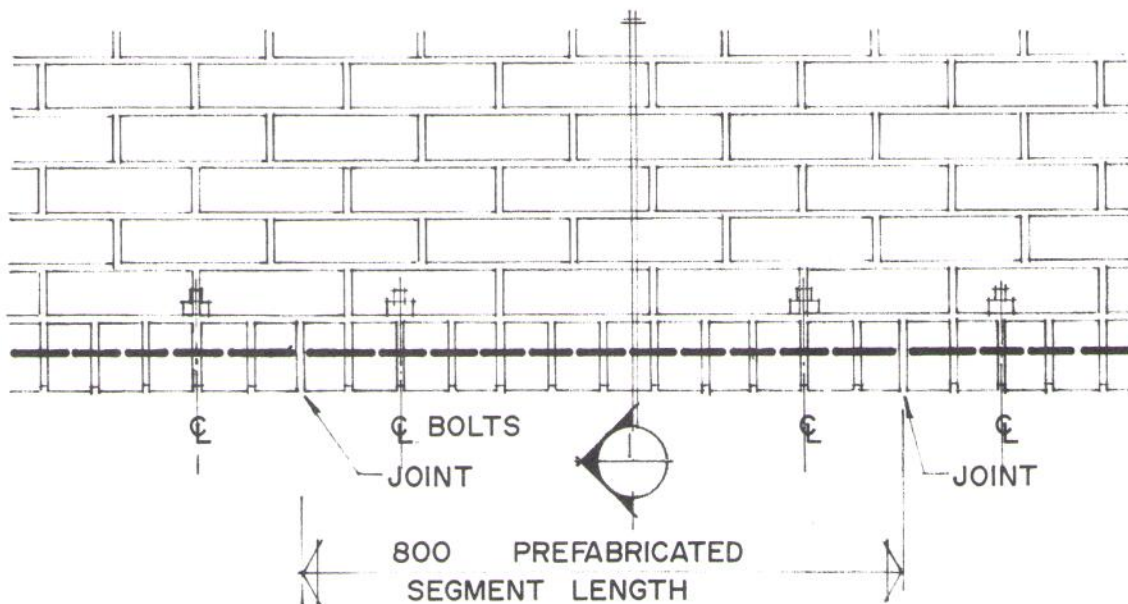
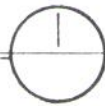

## ELEVATION

Figure 5: Brick Rowlock Course Shelf Angle Cover

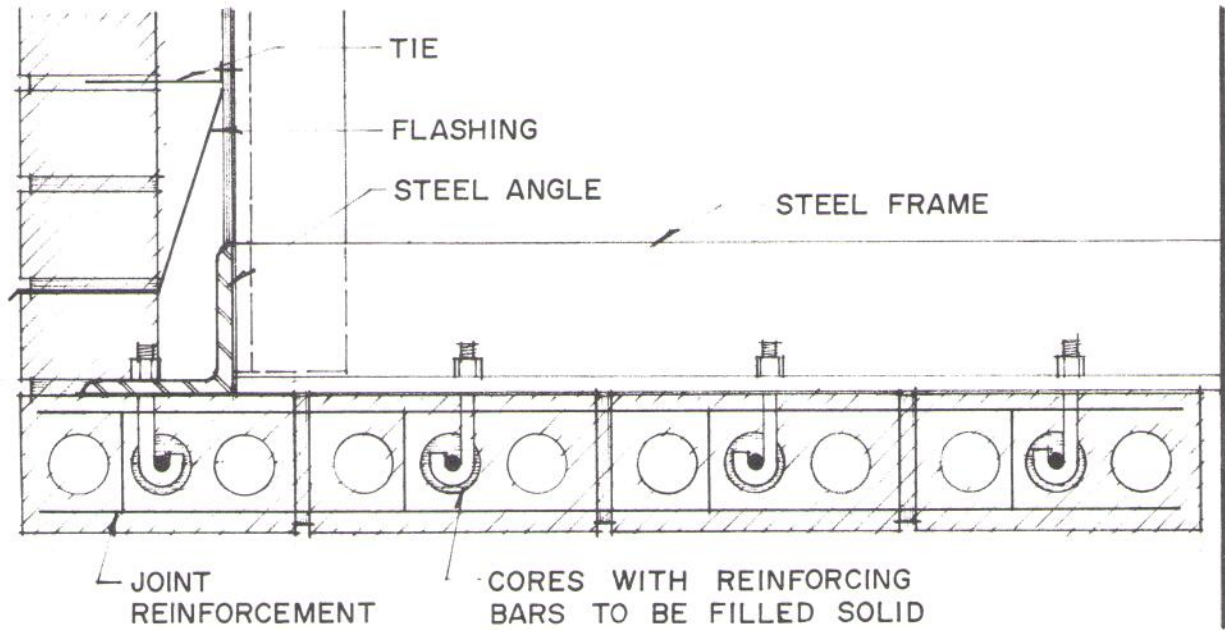

## SECTION INSTALLED

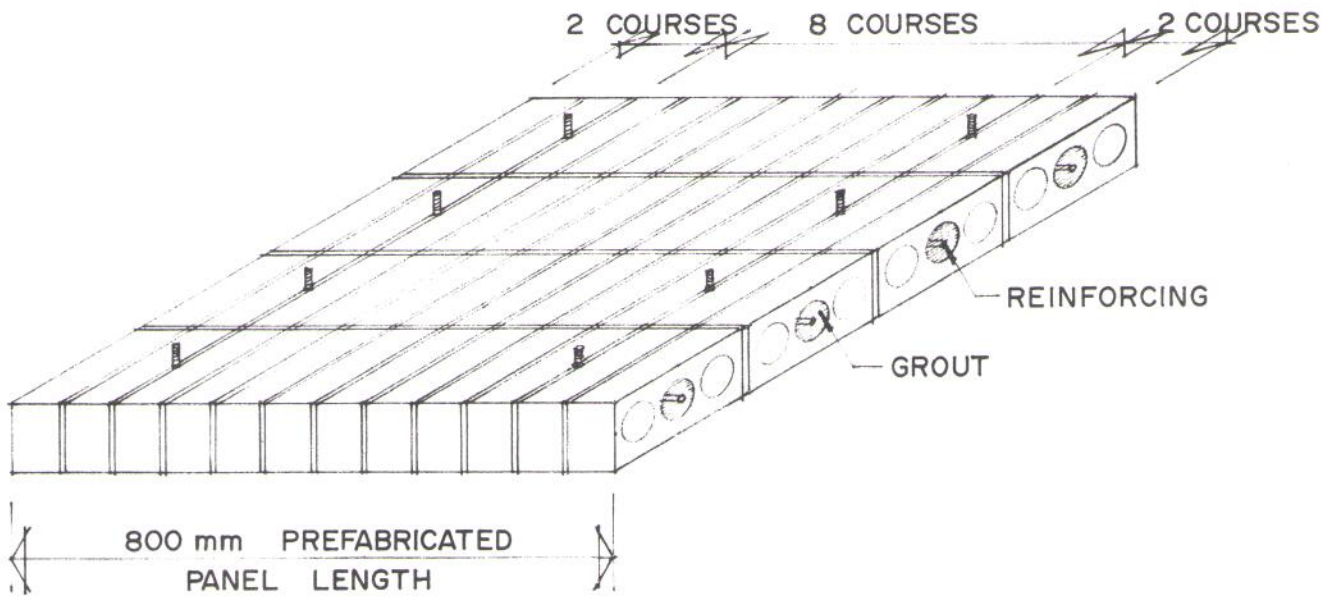

## VIEW · READY FOR INSTALLATION

Figure 6: Prefabricated Brick Soffit

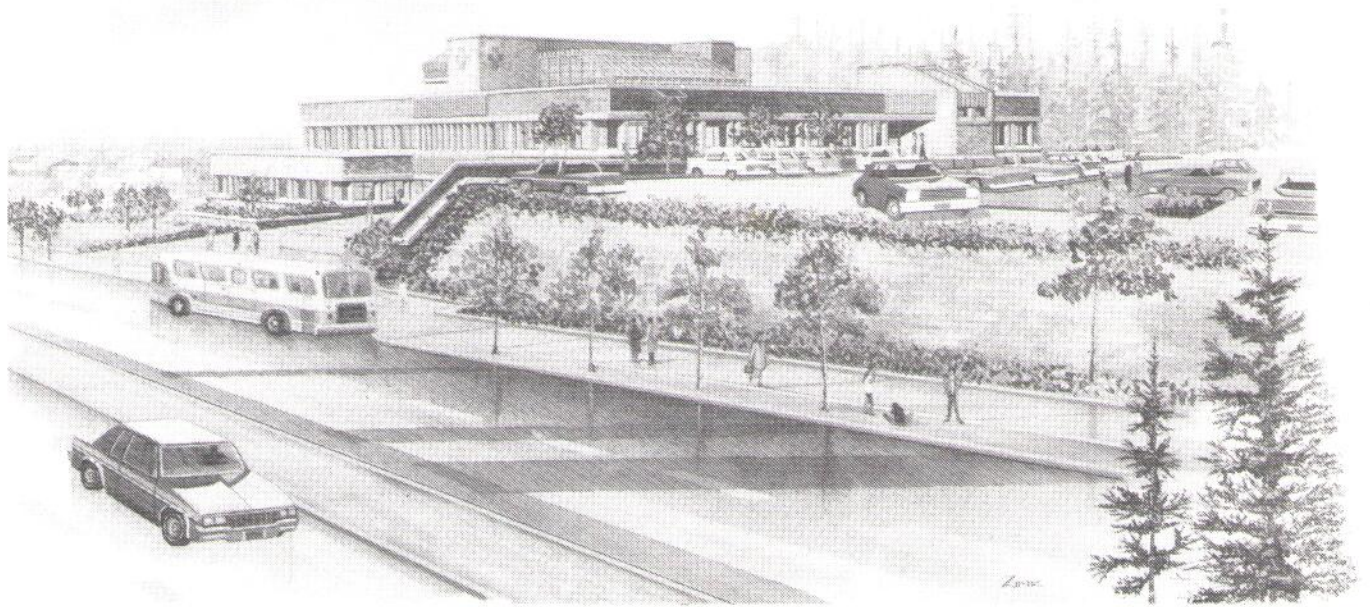
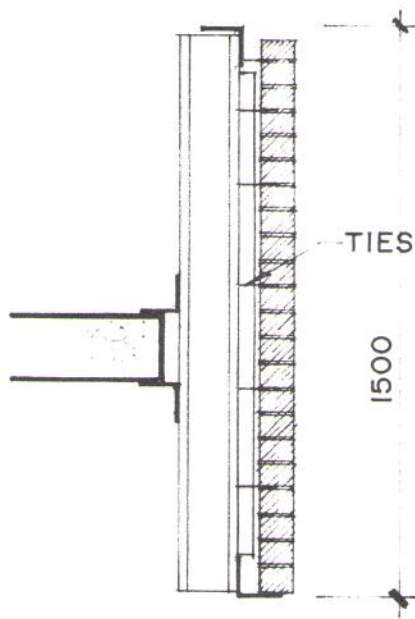

Figure 7: Views of Structure Utilizing Prefabricated Masonry Panels



**SECTION**

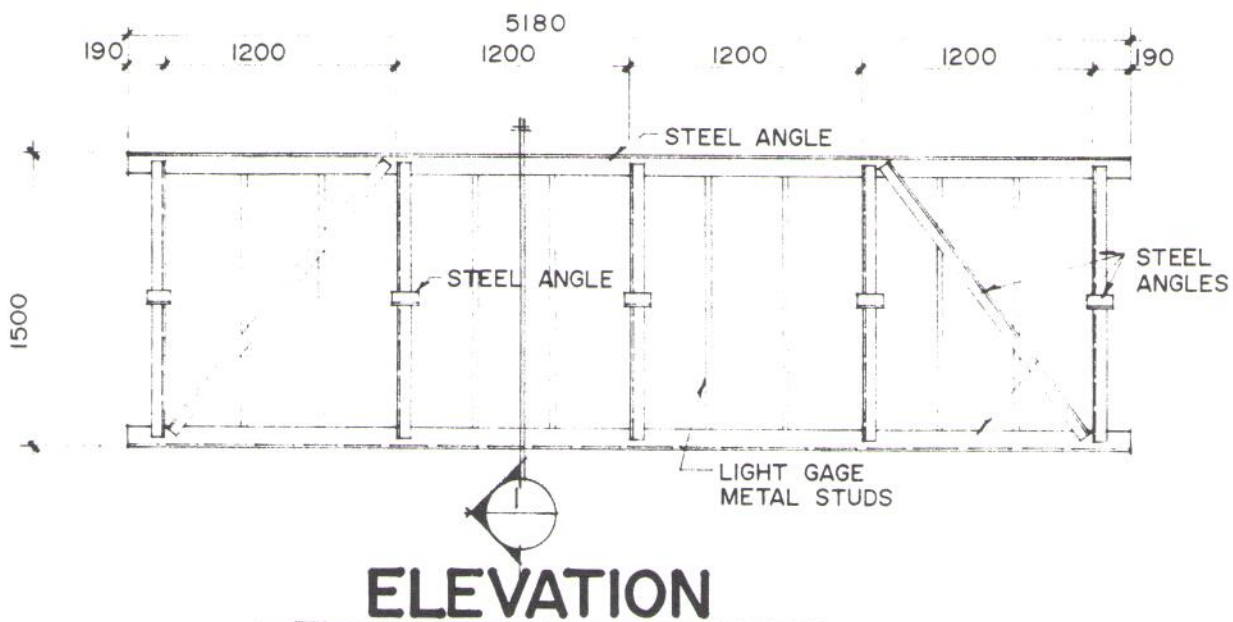

Figure 8: Prefabricated Panel with Steel Back-up Frame

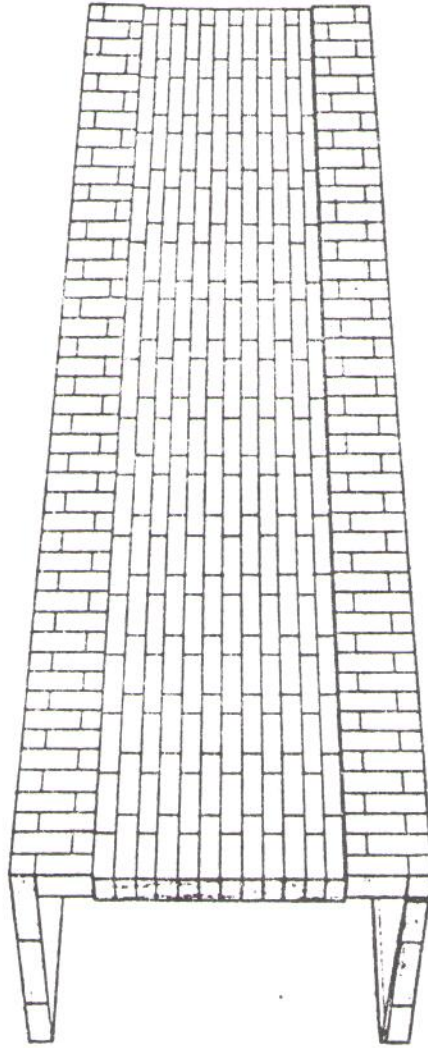
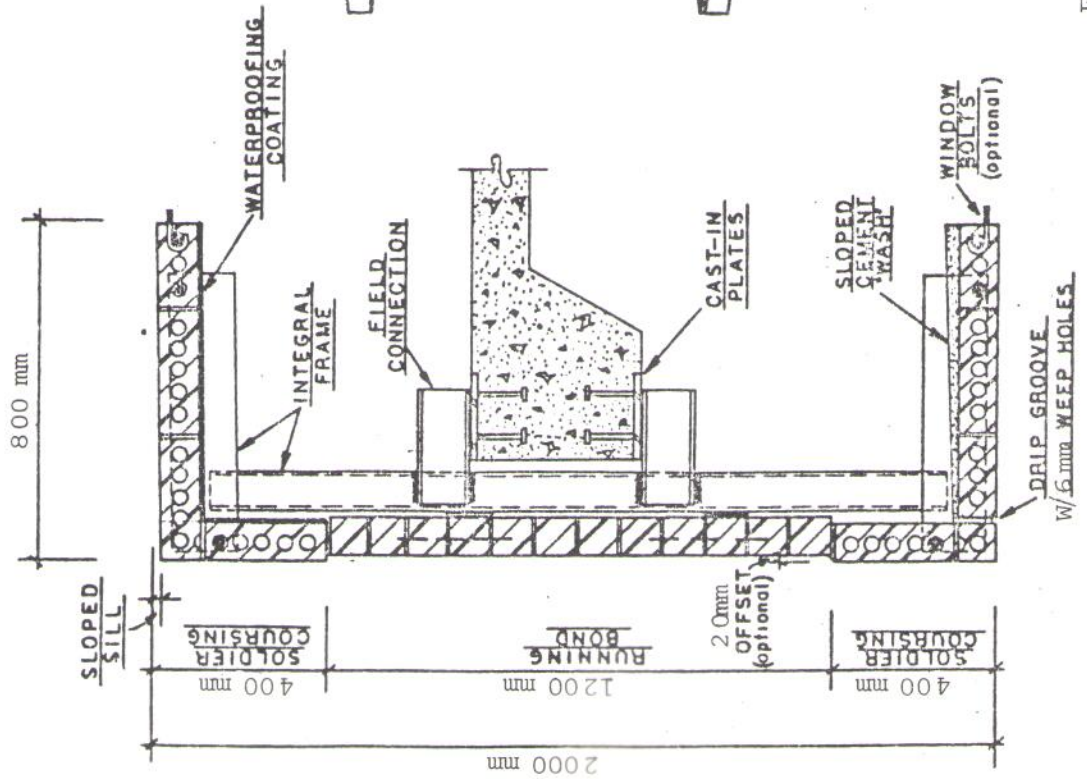

Figure 9: Prefabricated Brick Spandrel



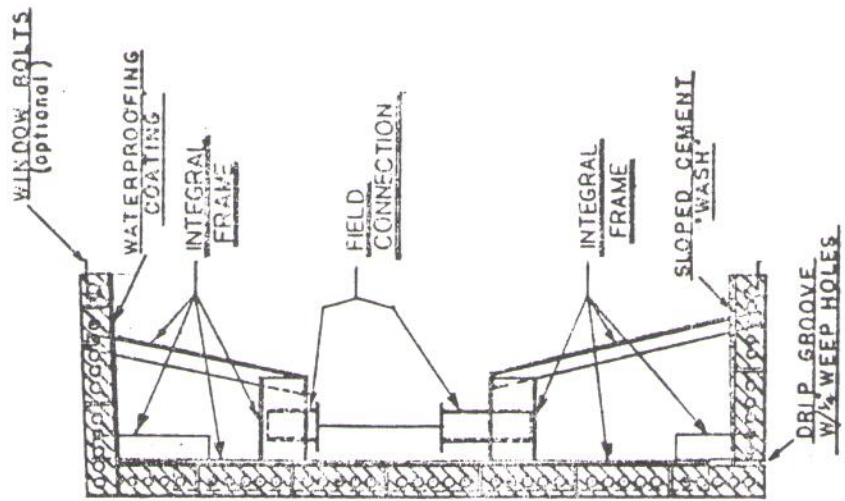
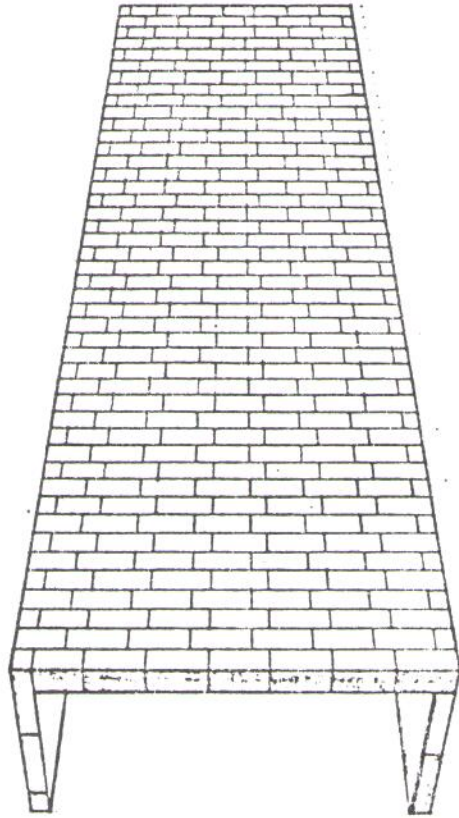

Figure 10: Prefabricated Brick Spandrel

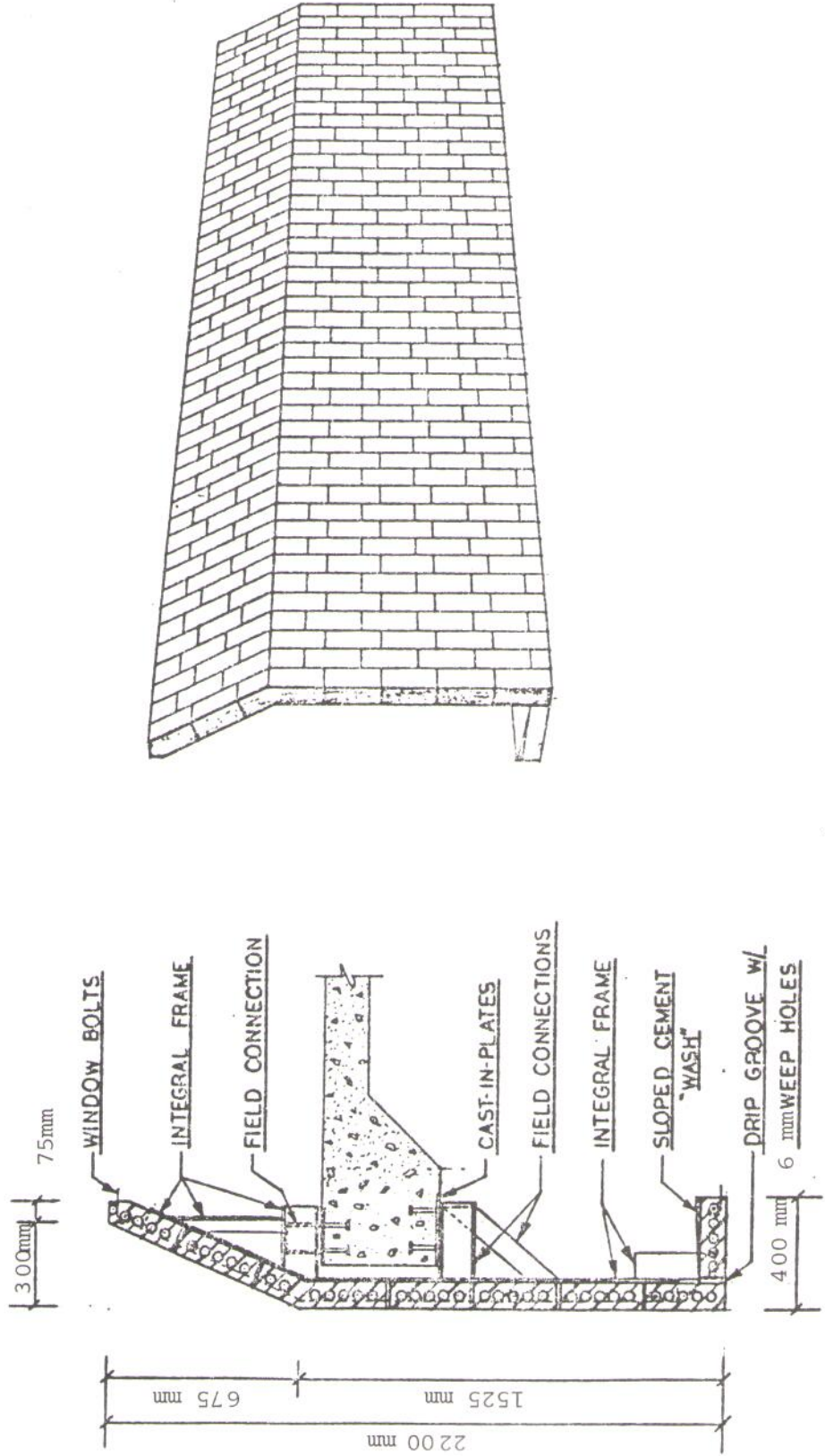

Figure 11: Prefabricated Brick Spandrel

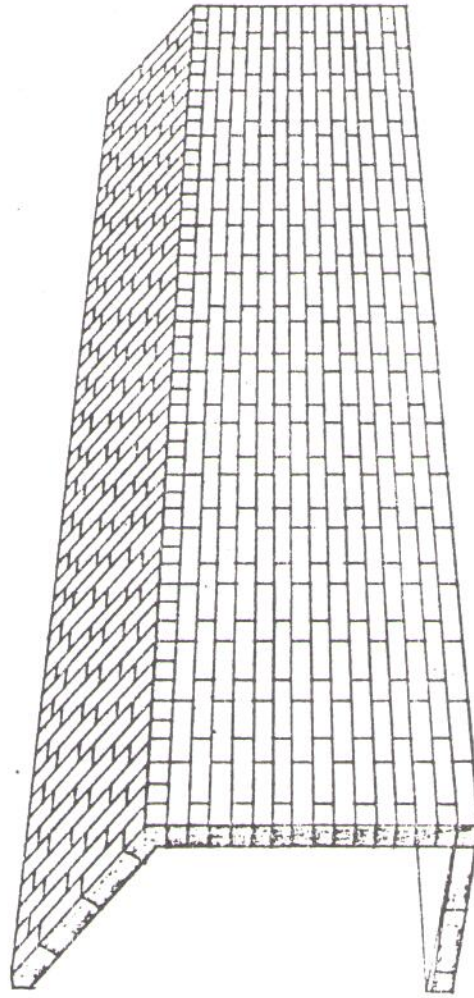
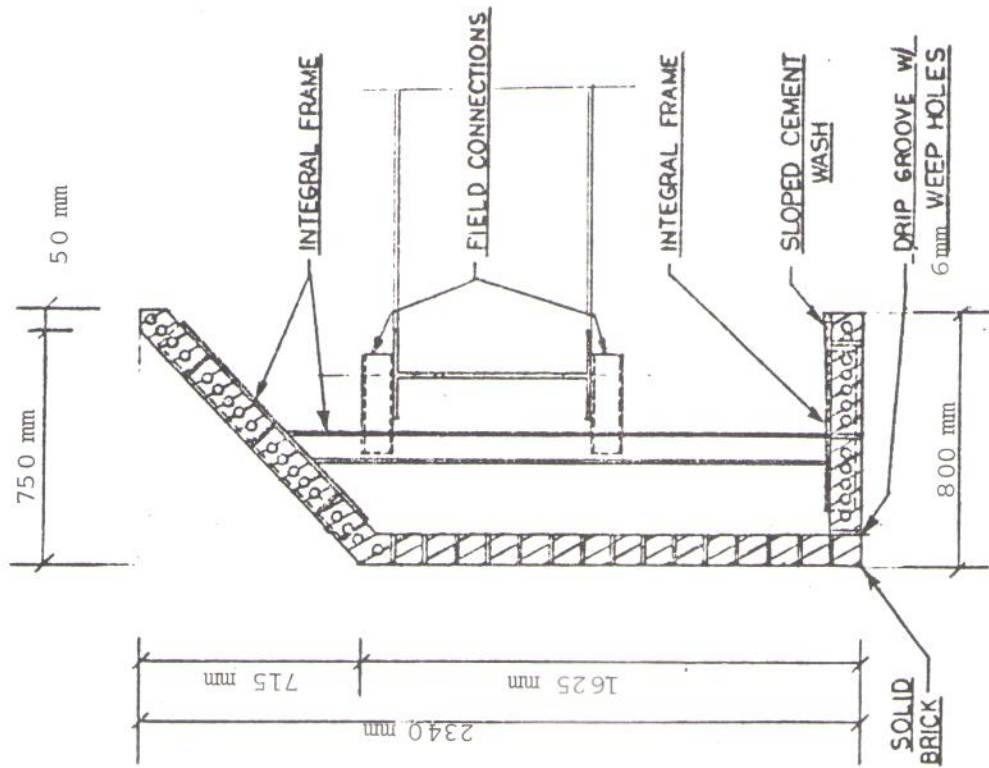

Figure 12: Prefabricated Brick Spandrel

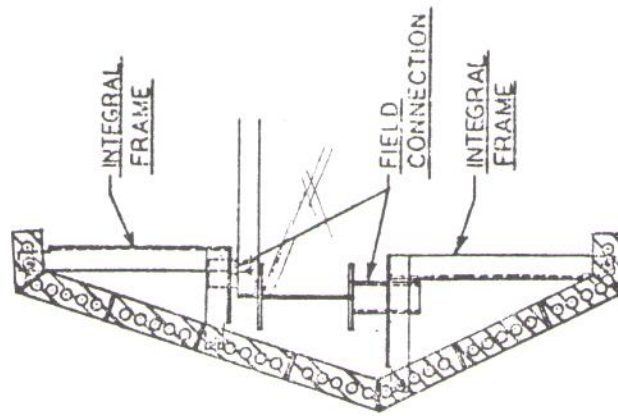
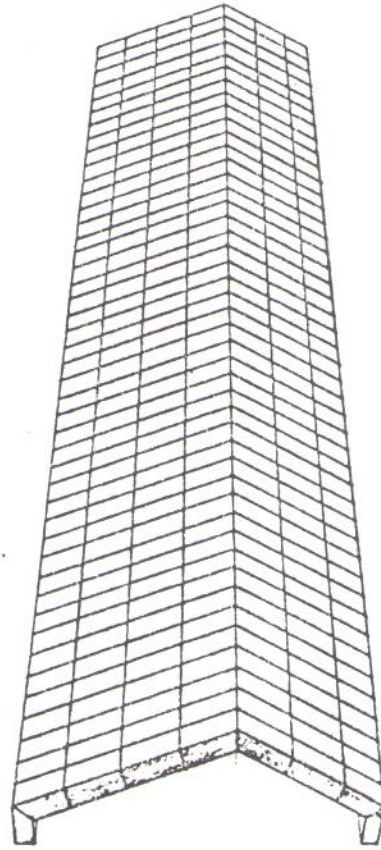
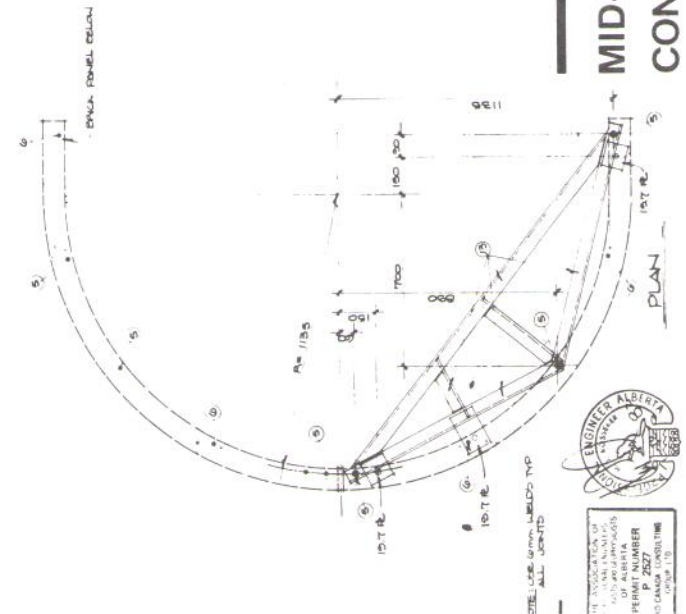
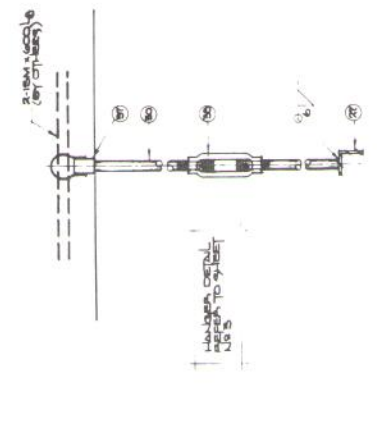
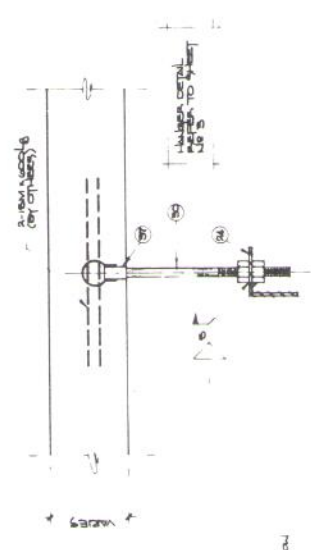
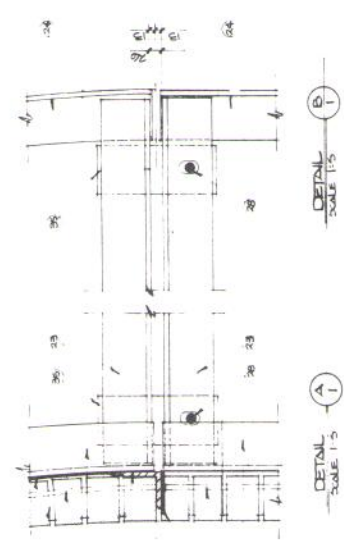
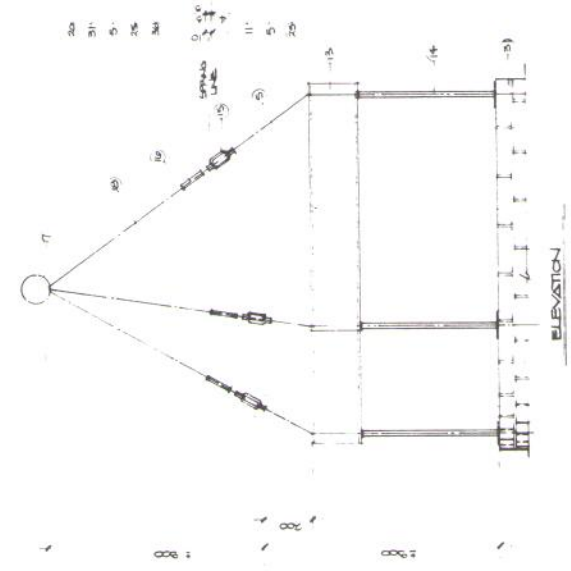
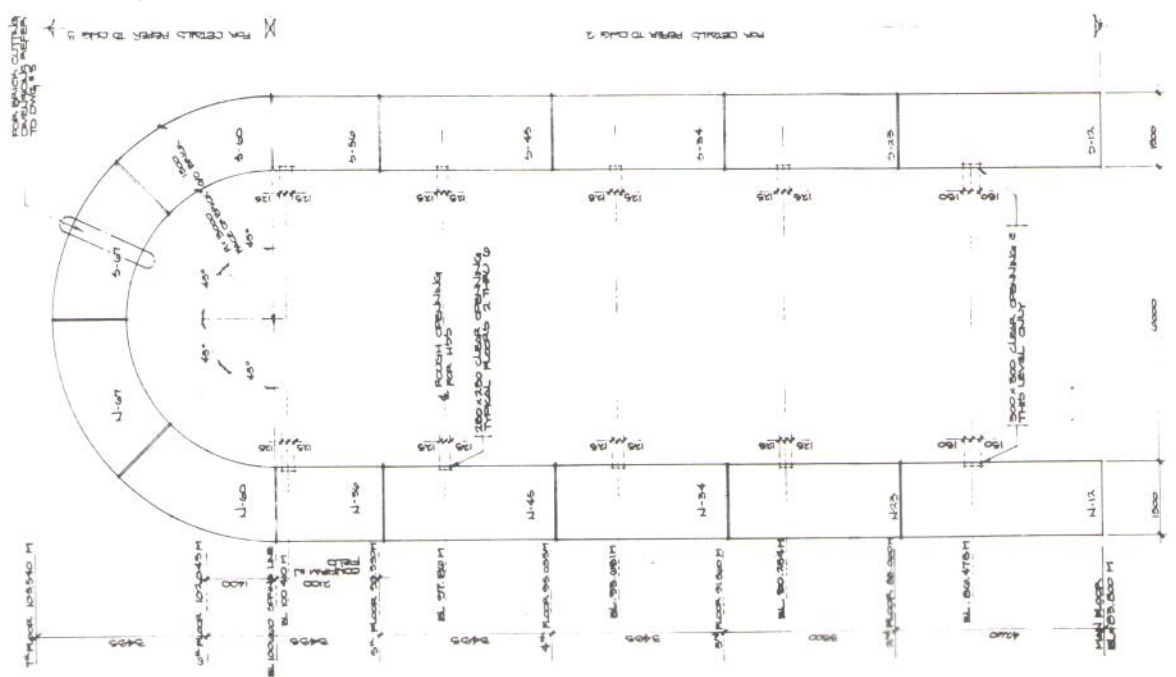

Figure 13: Prefabricated Brick Spandrel



NOTE: ALL DIMENSIONS ON SITE PRIOR TO ANY FABRICATION.

PANEL LAYOUT

NOTE: USE DIMENSIONS IN ALL UNITS

ENGINEER ALBERTA  
 PERMIT NUMBER  
 P-2527  
 WILSON, 1970

Figure 14: Semi-cylindrical Arch Details - Sheet No. 1



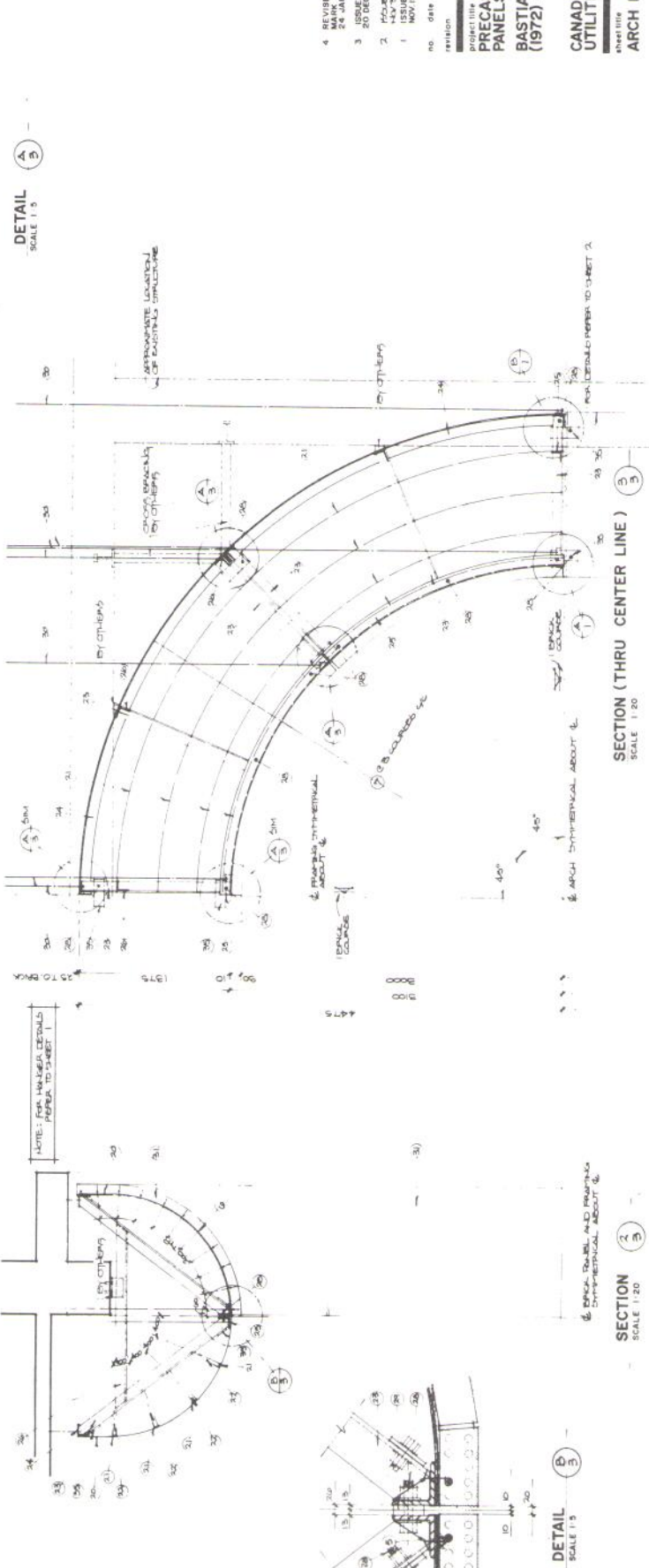
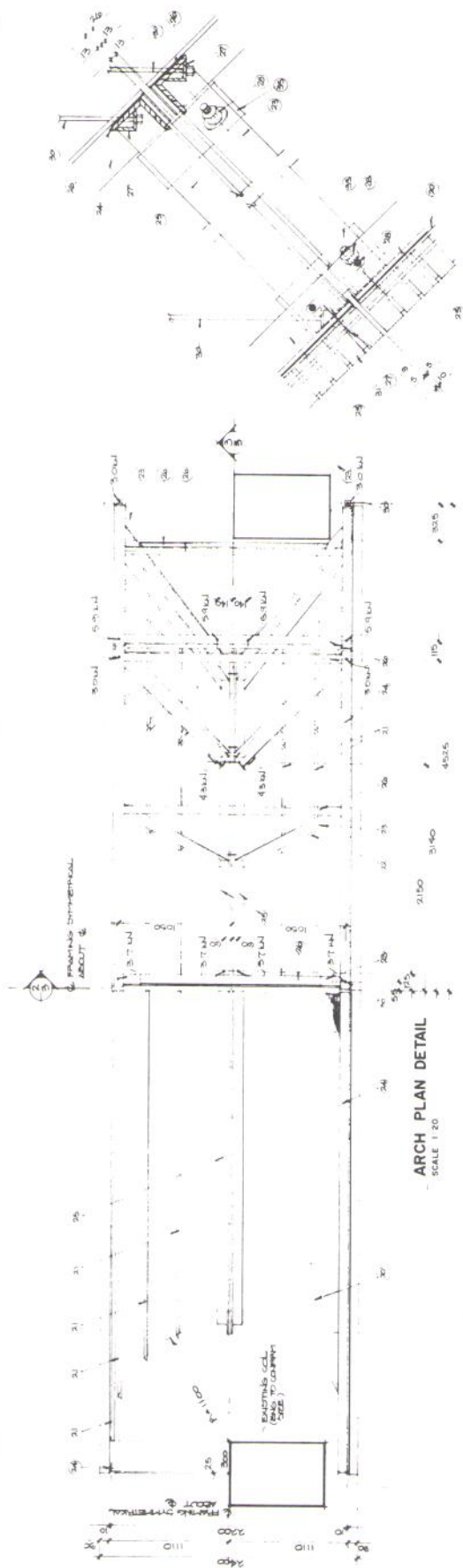

4. REVISED AS PER APPROVAL  
MARK UP PRINTS  
20 MAR 82 W.P.P.
3. REVISED AS PER APPROVAL  
MARK UP PRINTS  
20 MAR 82 W.P.P.
2. FOUND FOR REVIEW  
14 FEB 1982  
1. ISSUED FOR REVIEW  
10/18/1982 W.P.P.
- no. date by

PROJECT: **PRECAST BRICK PANELS BASTIAN MASONRY (1972) LTD.**

CLIENT: **CANADIAN UTILITIES BUILD.**

SHEET TITLE: **ARCH DETAILS**

Figure 16: Semi-cylindrical Arch Details - Sheet No.3

DATE: NOV 8 1982

CHECKED: [Signature]

PROJECT NO: 2105-006 3

SHEET NO: 3

**MID-CANADA CONSULTING GROUP LTD.**

REGISTERED ALBERTA PROFESSIONAL ENGINEER

ALBERTA PROFESSIONAL ENGINEERS ASSOCIATION

MEMBER NUMBER 101202

WILKINSON CONSULTING INC.

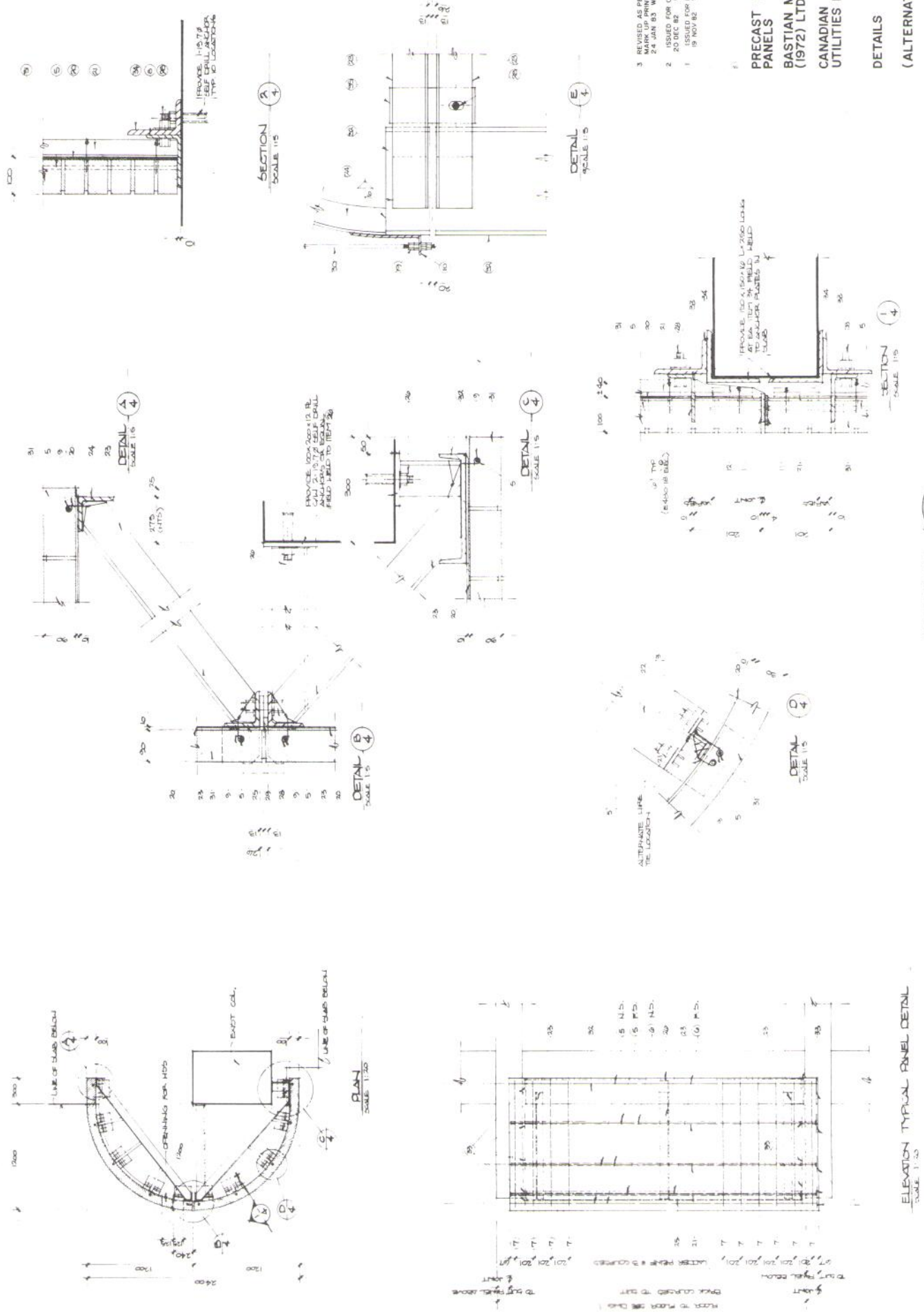

ELEVATION TYPICAL PANEL DETAIL  
SCALE 1/5

Figure 17: Semi-cylindrical Arch Details-Sheet No.4

3 REVISED AS PER APPROV  
MARK UP PRINTS  
24 JAN 83 WJP  
2 ISSUED FOR CONSTRUCTION  
20 DEC 82 WJP  
1 ISSUED FOR REVIEW  
19 NOV 82 WJP

PRECAST BRICK  
PANELS  
BASTIAN MASONRY  
(1972) LTD.  
CANADIAN  
UTILITIES BUILD.

DETAILS  
(ALTERNATE)

AS NOTED NOV 1982

118

2105.006 4







NOTE: MASONRY SHALL BE CONSTRUCTED ACCORDING TO THE CANADIAN MASONRY CODE (CMC) AND SHALL BE CONSTRUCTED TO BE FULLY RESPONSIBLE FOR THE ARCH.

TYPICAL COURSING  
SCALE 1:10

100.9	100.9
94.3	94.3
90.4	90.4
87.9	87.9
86.7	86.7
87.7	87.7
79.7	79.7
76.1	76.1
75.1	75.1
70.6	70.6
69.7	69.7
64.8	64.8
67.7	67.7
67.8	67.8
67.3	67.3



PROFESSIONAL ENGINEER  
PROVINCE OF ALBERTA  
PERMIT NUMBER  
2105-006  
NO. 117

ELEVATION  
SCALE 1:10

1. SIGNED FOR CONSTRUCTION  
BY THE ARCHITECT  
DATE: 11/11/77  
PROJECT: PRECAST BRICK  
PANELS  
BASTIAN MASONRY  
(1972) LTD.  
CANADIAN  
UTILITIES BUILDING  
BRICK CUTTING  
DETAILS  
AS NOTED NOV. 1977  
2105-006 5

Figure 18: Semi-cylindrical Arch Details - Sheet No.5

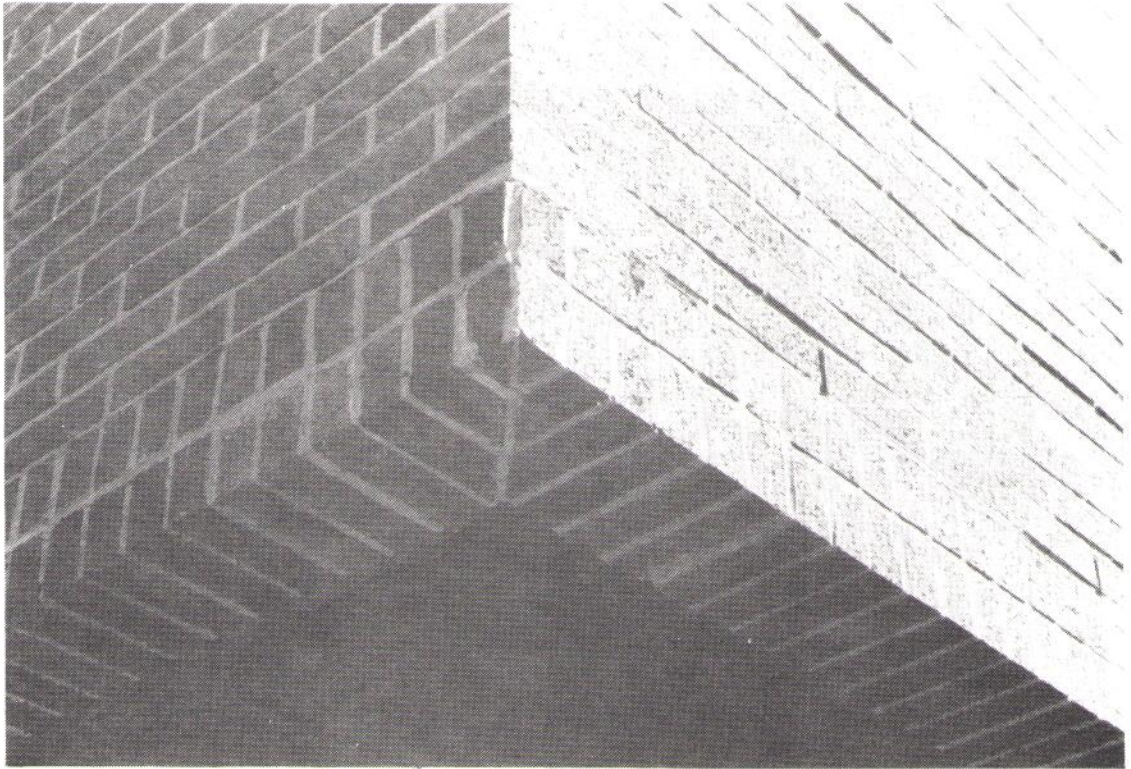

Photo 1: Brick Rowlock Course Shelf Angle Cover



Photo 2: View of St. Albert Place

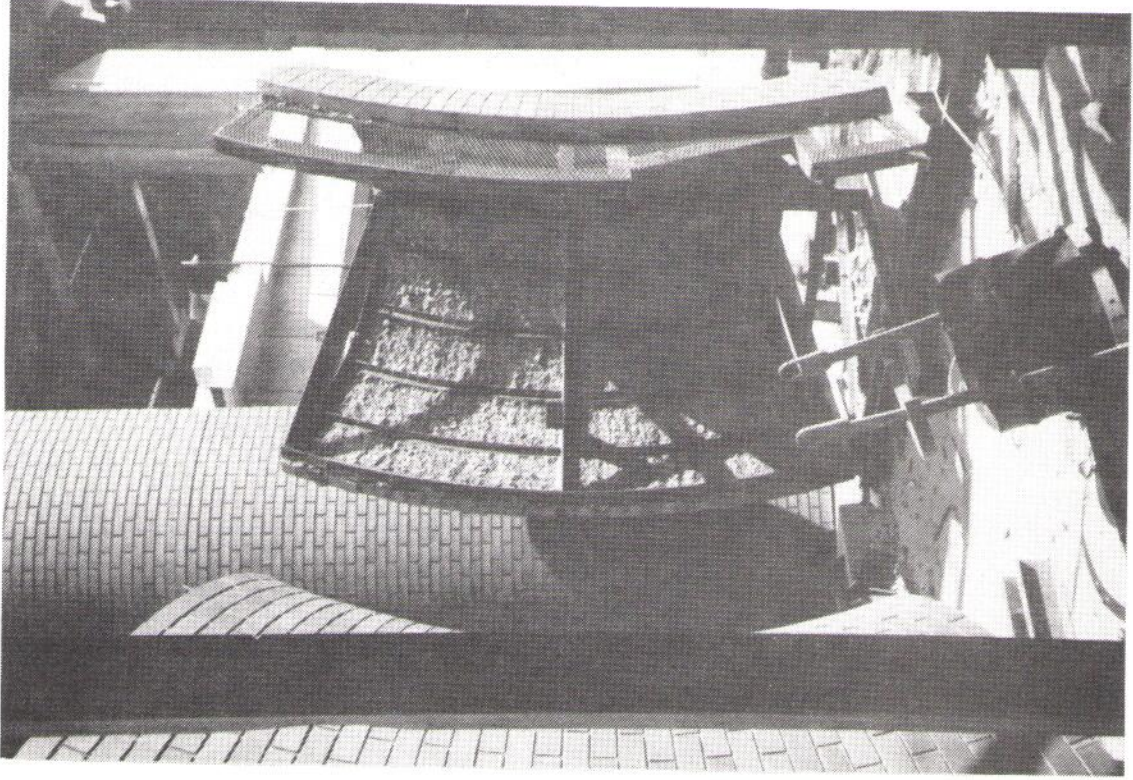

Photo 4: View of doubly curved segment of arch at the site

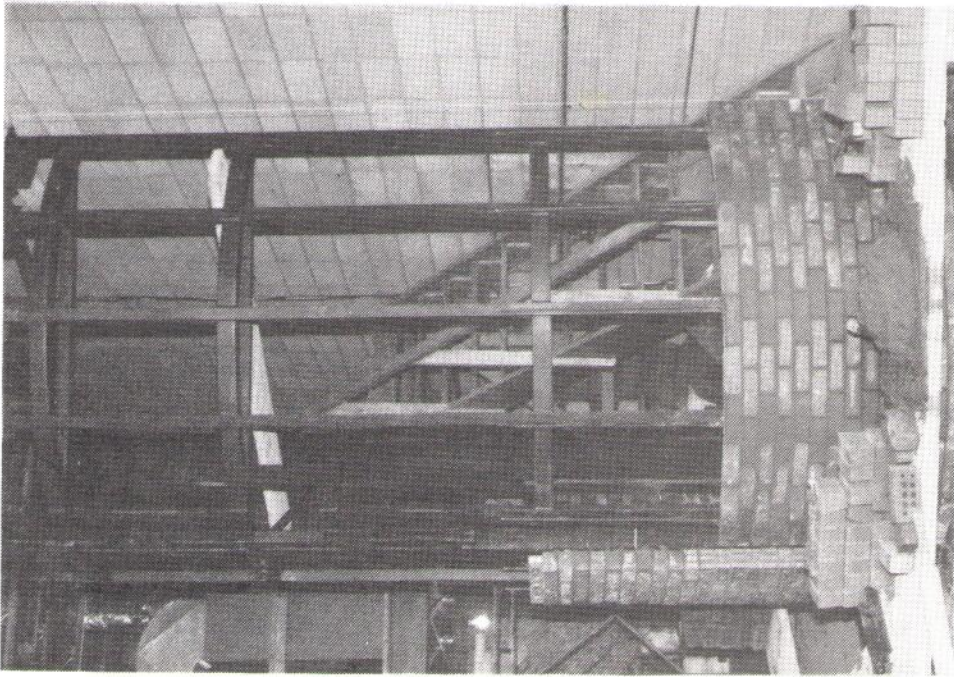

Photo 3: Vertical segment of arch under construction

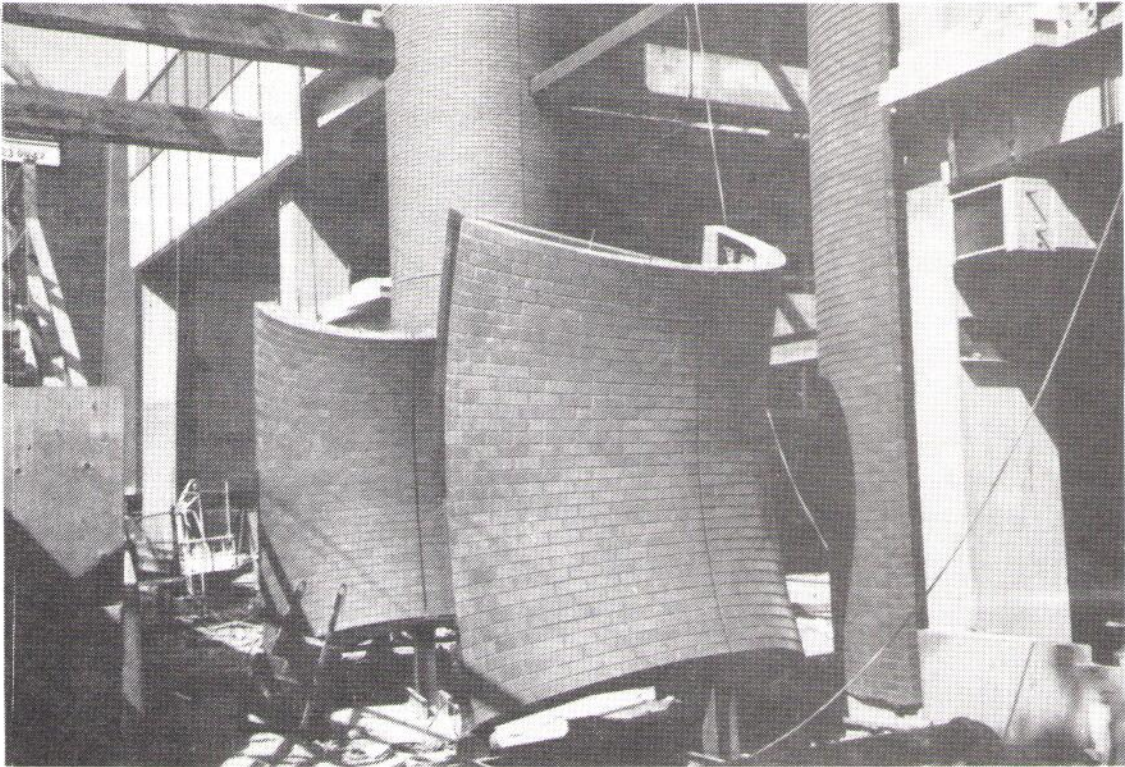

Photo 5: Segments of arch prior to hoisting into place



Photo 6: Detail of brick ties and fastening of prefabricated arch segment to the main structural elements

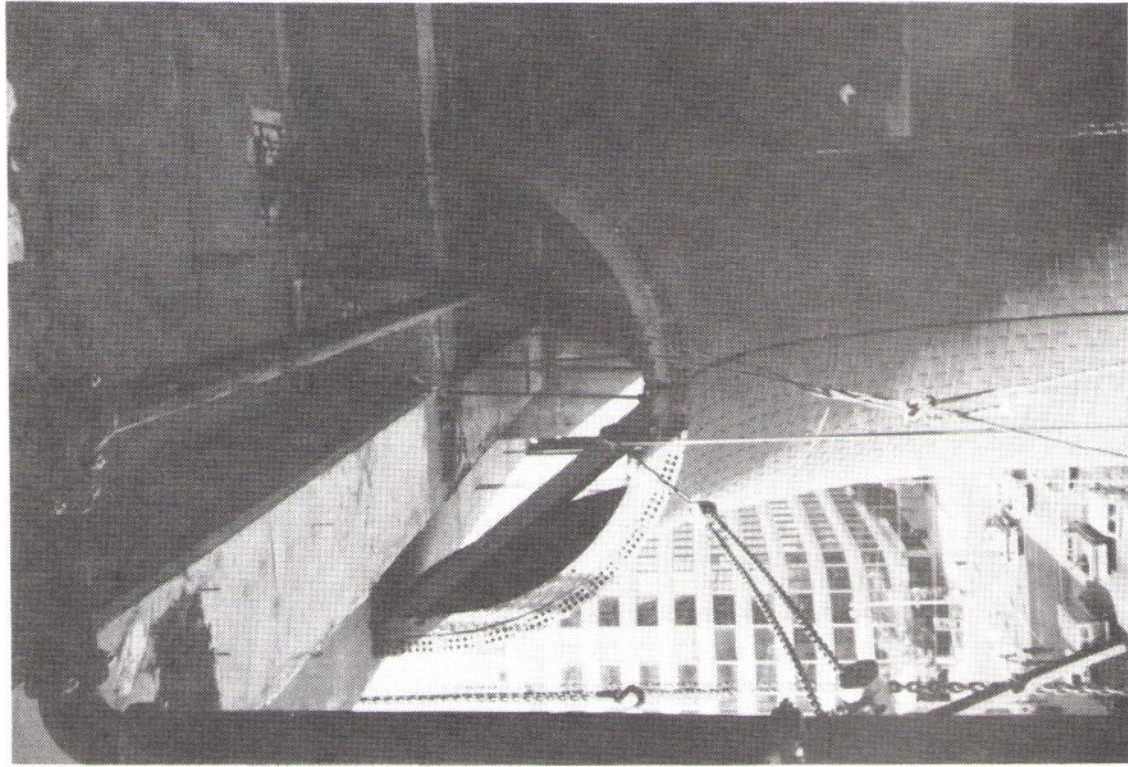

Photo 7: Doubly curved segment of arch during erection

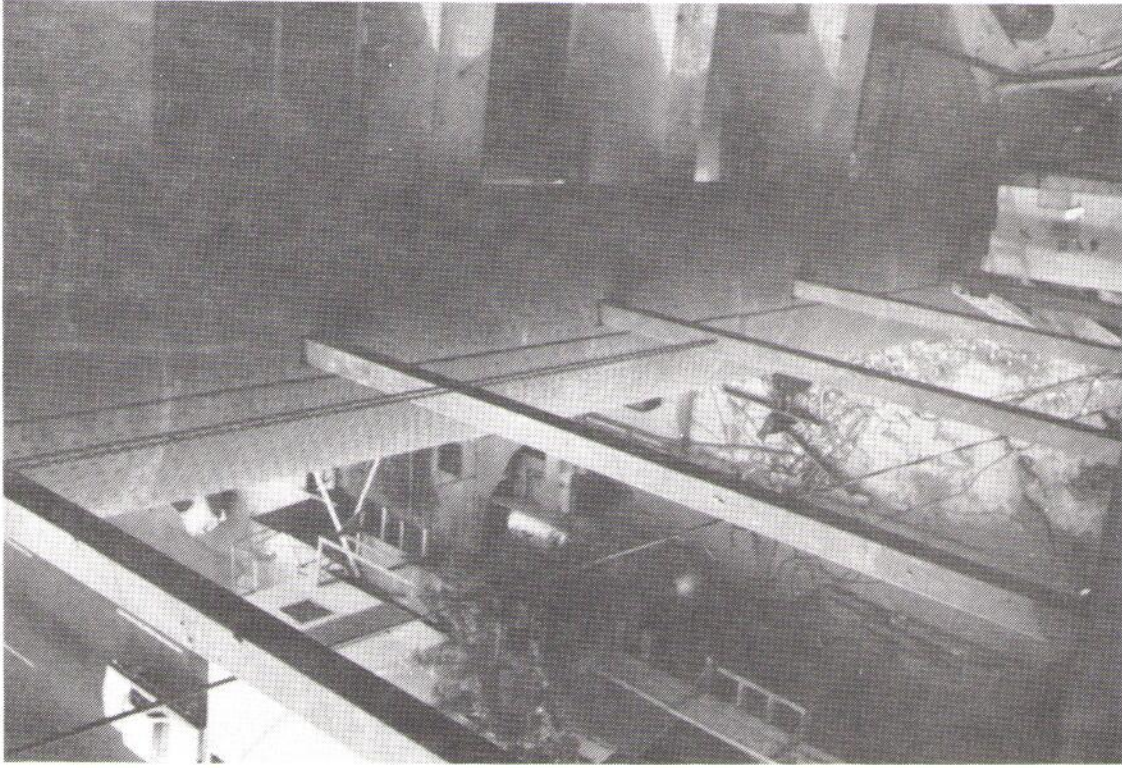

Photo 8: View of thermal separation

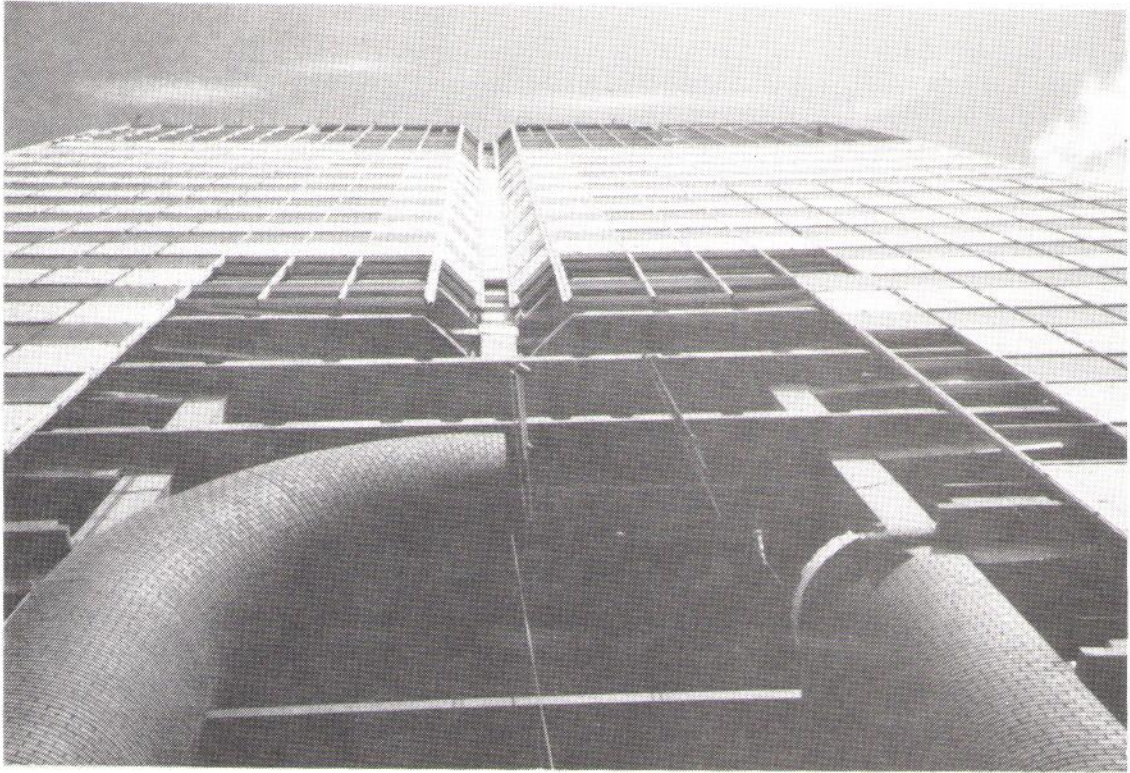

Photo 9: Final stages of erection

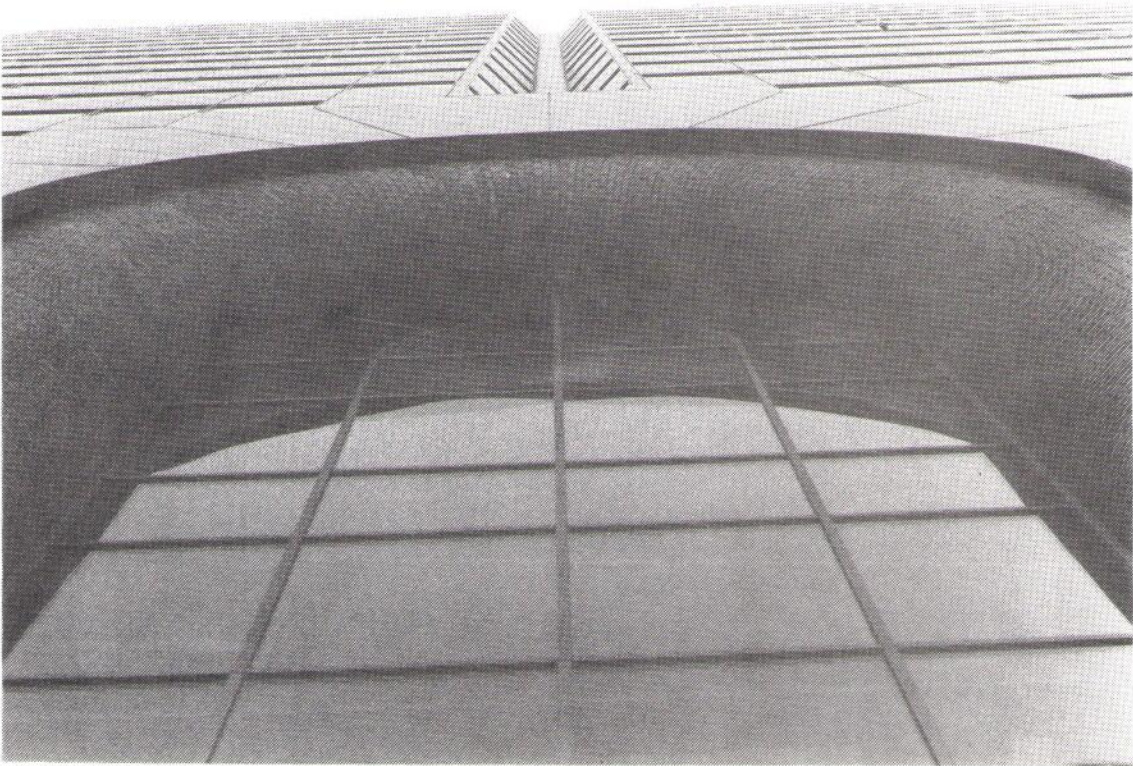

Photo 10: View of finished doubly curved portion of arch

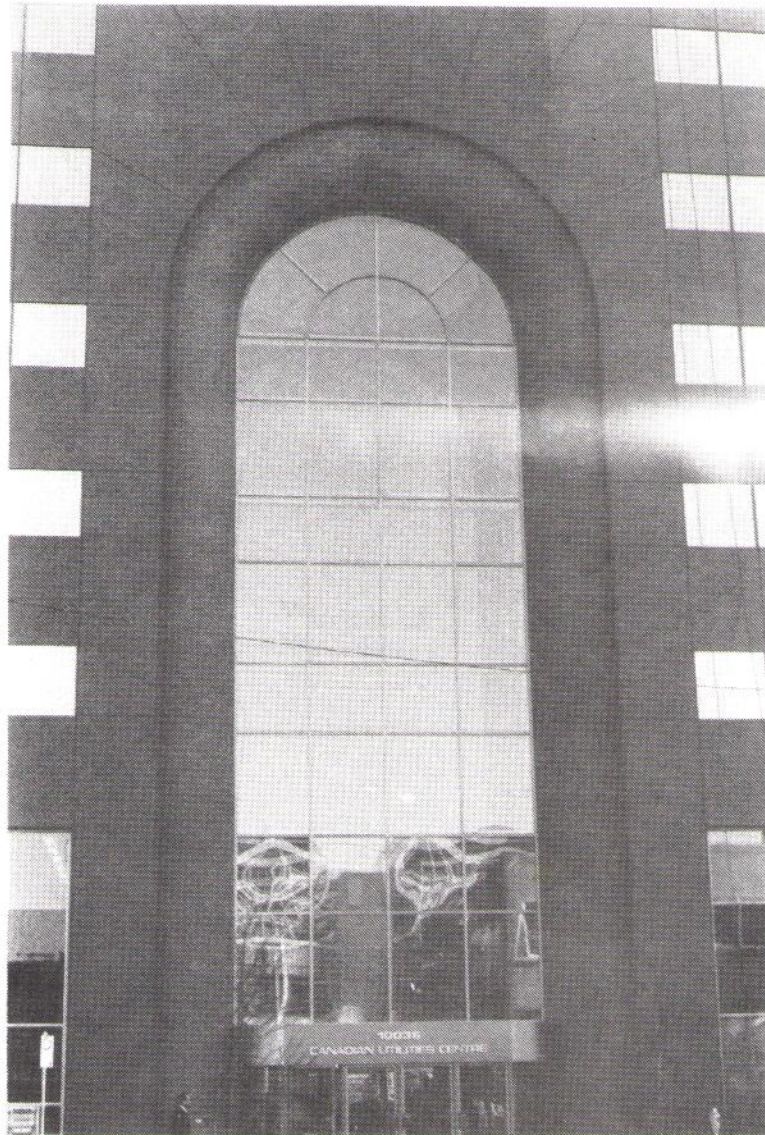

Photo 11: View of completed arch